

# Submersible Mixer Type ABS RW 200 and 280

# SULZER

## 60 Hz

Compact submersible mixer for flushing and cleaning of pump sumps.

### Applications

The compact submersible mixers of the RW 200 / RW 280 series are designed for mixing applications in pump sumps, i.e. the prevention of sedimentation deposits and floating scum. They have a maximum continuous running time of one hour, and up to a total of eight hours in every twenty four.

The RW 200 / 280 series can be installed regardless of the tank shape and is suitable for the cleaning of pump sumps up to Ø 5 m or 24 m<sup>2</sup>. Depending on the intensity of mixing required, one or more mixers may be installed.

The optimum flow direction for a particular application can be achieved quite simply by adjusting the mixer position horizontally or vertically ( $\pm 30^\circ$ ) on the mounting bracket.

Horizontal adjustment is not possible in a guide rail installation. In a hanging installation, swivelling in the horizontal plane is facilitated by the conical threaded pipe connection.

The coupling bracket, adjusting plate, and 10 m cable with free cable ends, are supplied as standard.

**For optimum selection in general mixing applications the following information is required:**

- Application
- Tank / sump dimensions
- Medium to be mixed
- Viscosity and specific weight of medium
- Temperature, dry matter content etc.

### Construction

- Water-pressure-tight encapsulated modular motor with cast iron housing, oil chamber and propeller, form a compact, robust, unit construction.
- Single- and three-phase, 4-pole motor, 1 450 minimum r/min, insulation class F, protection class IP 68.
- Rotor shaft supported in lubricated-for-life ball bearings.
- Tandem shaft sealing with lip seal and silicon carbide mechanical seal as standard; option of Viton double mechanical seal.
- Patented solids deflection ring protects the mechanical seal from damage by ingress of solid or fibrous matter.
- Blockage-free, cast iron, 2-blade propeller.
- Thermal sensors in the stator give a warning and switch off the unit if excessive temperatures are reached in the motor.
- Maximum allowable temperature of the medium is 40 °C.

### Materials

Description	Material
Motor housing	Cast iron EN-GJL-250
Motor shaft	Stainless steel 1.4021 (AISI 420)
Oil chamber	Cast iron EN-GJL-250
Propeller	Cast iron EN-GJL-250
Fasteners	Stainless steel 1.4401 (AISI 316)



### Features

- Easy installation
- Small space requirements
- Adjustable bracket allows direction to be altered
- Guide rail mounting option
- Cast iron housing
- Wear-resisting propeller
- High power reserves
- Patented solids deflection ring
- Modular motor
- Available as standard or explosion-proof

**Identification code:** e.g. RW 2022 13/4 Ex

#### Hydraulics:

RW.....Mixer series  
 20 .....Propeller diameter (cm) nominal  
 2 .....Propeller type  
 2 .....Hydraulic number

#### Motor:

13 ..... Motor power  $P_2$  kW x 10  
 4 ..... Number of poles  
 Ex ..... Motor version (EX only on request)

### Accessories

Description	Part no.	
Mounting brackets	wall or floor	62995000
	wall (extended)	62990006
	pipe G 1½"	62990007
	guide rail 60 x 60 mm open	61265048
	guide rail 60 x 60 mm closed	61265049
	guide rail 50 x 50 mm open	61265050
Concrete base	guide rail 50 x 50 mm closed	61265051
		62990008

## Technical Data

RW	2022	2022	2821
Motor	S16/4	S18/4	S28/4
Propeller diameter [mm]	200	200	280
Propeller angle	16°	16°	16°
Speed [r/min]	1 750	1 750	1 750
Motor power [kW]*	$P_2 = 1.57$	$P_2 = 1.79$	$P_2 = 2.83$
Rated voltage [V]	Three phase 208, 230, 380 460, 575	Single phase 115 (not Ex) 208, 230	Three phase 208, 230, 380 460, 575
Rated current [A]: 230 V 460 V 575 V	7.2 3.6 2.9	12.1 - -	10.9 5.5 4.4
Cable type	SOW-A 14/7	SOW-A 14/7	SOW-A 14/7
Cable length [m]	10, 20, 30, 40, 50	10, 20, 30, 40, 50	10, 20, 30, 40, 50
Weight [kg]	25.85	31.75	31.75

\*  $P_1$  = Power taken from mains.  $P_2$  = Power at motor shaft.

## Maximum Tank Sizes

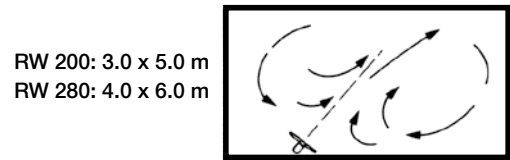
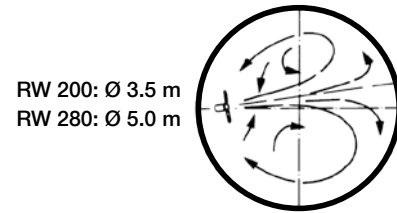

## Dimensions (mm)

### Guide rail

for easy installation and removal

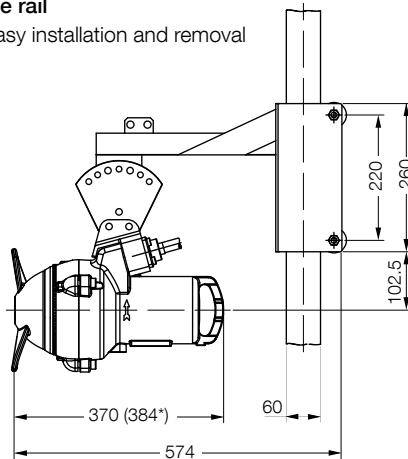

\* RW 280

### Wall mounted

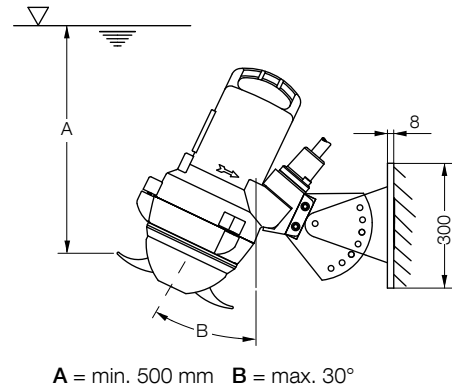

### Floor mounted

on moveable concrete base

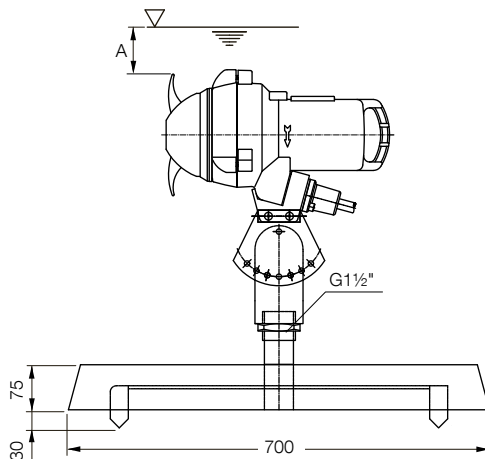

A = min. 400 mm

### Hanging installation

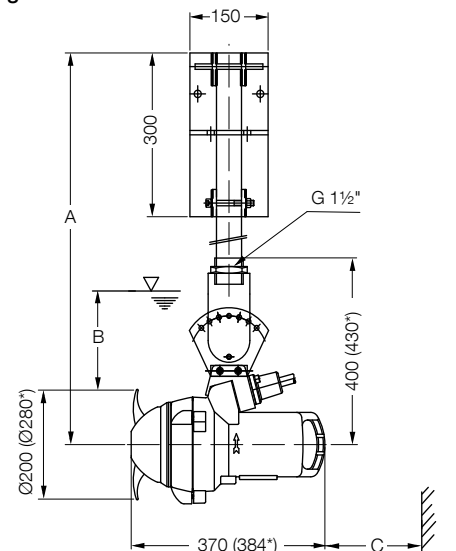

A = max. 2 m B = min. 400 mm C = min. 450 mm

\* RW 280