

Lifting Station Type ABS Synconta 700

SULZER

Synthetic prefabricated sump, designed as a single pumping station for the effective dewatering of buildings and areas below the sewer level. Designed as a complete wastewater sump for internal (above-ground), or external (below-ground) installation, and for fitting with selected pumps from the Piranha range. Synconta 700 is suitable also for the pumping of sewage containing faecal matter.

Features

- Robust construction with lockable hollow lid which can be foam-filled for added insulation.
- For external installation a special cast iron sump cover is required for protection against overhead traffic (in accordance with EN 124; Group 1 permissible traffic tonnage 5 kN/m²).
- Stainless steel discharge pipe with 1 1/4" external thread.
- Single DN 100 inflow port for DIN push-on connection. One port DN 70 for venting and use as a cable duct (supplied as standard with plug/cable inlet seal).
- Available with optional polystyrene jacket to insulate against noise and excessive external temperatures.
- Simple pump installation and maintenance. The pump seals automatically onto the discharge line when lowered into the high-level coupling.
- Automatic pump and level control by pressure sensor system (Piranha-S) or KS float switch (Piranha 09).
- Maximum allowable temperature of medium 40 °C, short term to 60 °C (max. 5 minutes).

Installation

Attention to the backwash level is of vital importance for effective dewatering. All outflow points located below the backwash level must be protected against back flow according to standard EN 12056.

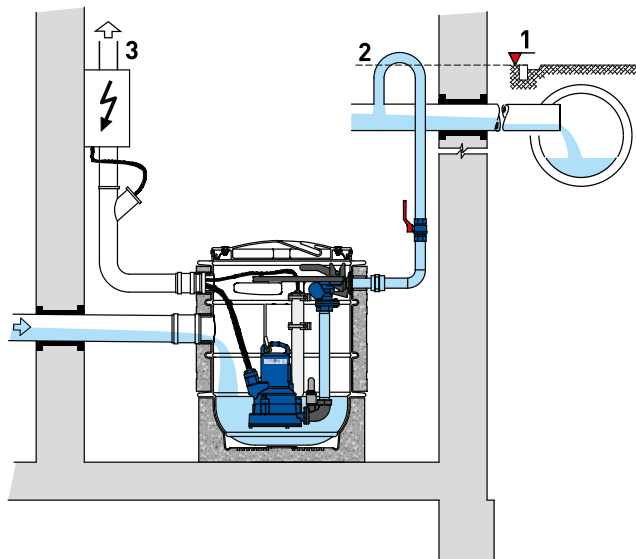

1. Backwash level.
2. Discharge pipe. Must rise above backwash level before entering sewer line.
3. External ventilation pipe.

Rooms for sewage lifting stations must be large enough that a working area of at least 60 cm width or height is available around all parts which have to be operated or maintained.



Tank

Synthetic, corrosion-resistant tank supplied as standard with plastic lid, discharge pipework and coupling with non-return ball valve. Pump, pressure sensor, control panel, sump cover and insulation jacket are not included.

Capacity: 190 litres

Weight: 35 kg (includes installation pipework but not weight of pump).

Motor

Three phase, water pressure sealed, squirrel cage 2-pole induction motor with double shaft seals and oil chamber.

Insulation: Class F (155 °C)

Protection type: IP 68

Pump type

Submersible grinder pump type ABS Piranha with shredding system hydraulics which can cut and pump wastewater containing solids through small diameter discharge lines from 1 1/4".

Performance curves

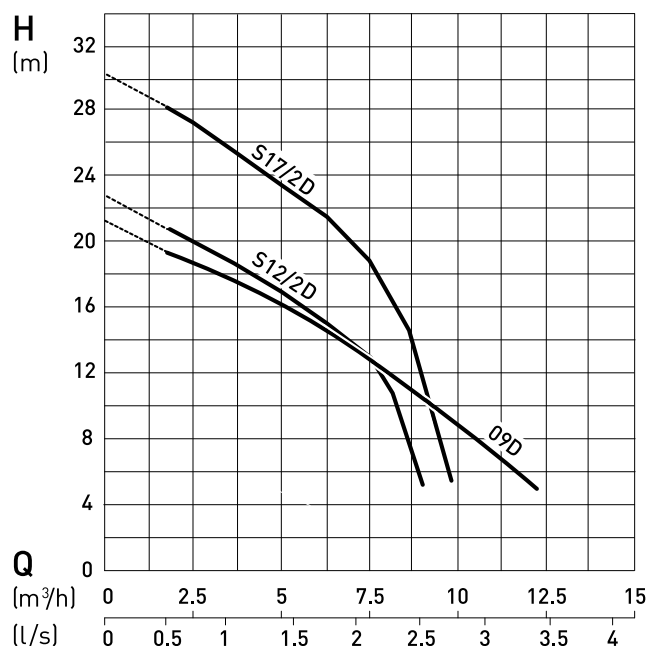

H = Total head. Q = Discharge volume. Curves to ISO 9906.

Technical data

Piranha	Discharge Pipe		Motor power *		Rated current (A)	Rated voltage ** (V)	Speed (r/min)	Cable *** (H07RN-F)	Pump weight (kg)
	Pump (flange)	Pipe (thread)	P ₁ (kW)	P ₂ (kW)					
09/2D	DN 32	R 1¼"	2.56	2.00	4.64	400 3~	2900	4G1.0	23
S12/2D	DN 32	R 1¼"	1.69	1.20	3.29	400 3~	2900	4G1.5	32
S17/2D	DN 32	R 1¼"	2.31	1.70	6.90	230 3~	2900	4G1.5	32
S17/2D	DN 32	R 1¼"	2.31	1.70	3.97	400 3~	2900	4G1.5	32

* P₁ = Power at mains. P₂ = Power at motor shaft. ** 230 V can operate as single phase using the appropriate control panel (see accessory table).

*** Special rubber compound, free-end cable.

Dimensions (mm)

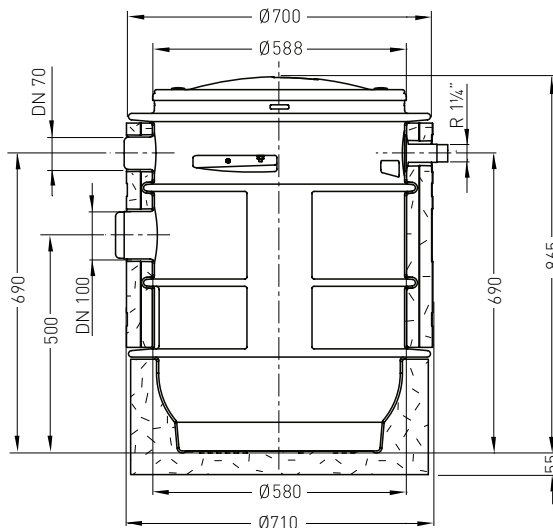
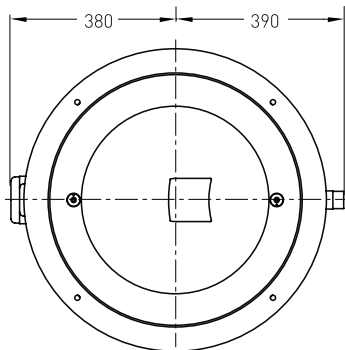

Inlet diameters

Ø	(mm)
DN 70	+0.2 Ø 75 -1.0
DN 100	+0.3 Ø 110 -1.0

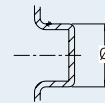

Sump cover

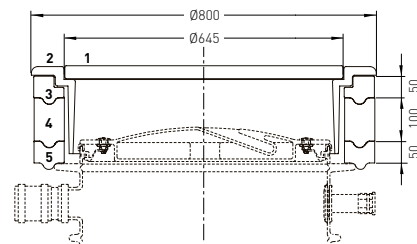

1. Cast iron lid
2. Cast iron frame
3. Synthetic frame-support ring
4. Concrete spacer ring
5. Synthetic support ring (sits on tank rib)

Materials

Description	Material	
Synconta 700	Tank and lid	Polyethylene
	Insulation jacket	Extruded polystyrene
	Discharge pipe	Stainless steel 1.4301 (AISI 304)
	Coupling and valve	Cast iron EN-GJL-250
Piranha pump	Upper lid *	Stainless steel 1.4301 (AISI 304)
	Motor housing	Cast iron EN-GJL-250
	Rotor shaft	Stainless steel 1.4021 (AISI 420)
	Impeller **	Cast iron EN-GJL-250
	Volute	Cast iron EN-GJL-250
	Fasteners	Stainless steel 1.4401

* Piranha 09. ** Polyamide for Piranha 09

Accessories

Description	Part no.
Insulation jacket	62665343
Pressure sensor (MD 126)	27007024
Pressure pipe kit	62665180
Vacuum breaker	62665297
Sump cover - for below-ground installations	On request
Control panel: CP114: 230 V single phase, 7.5 A	62160870
CP112: 230 V three phase	15207147
CP112: 400 V	15207145