

**SLUDGE MASTER®**  
SEVERE DUTY PLUNGER PUMPS  
**HPE SERIES**

**PUMP MODELS**

HPE 1141 Simplex

HPE 1142 Duplex

HPE 1143 Triplex

HPE 1144 Quadruplex

**FEATURES**

TRANSFER UP TO 556  
GPM

160,000 PSI STRENGTH  
SHAFTS

REPLACEABLE BRONZE  
INSERT

LOWER COST PARTS

LEAK RESISTANT DESIGN

PLUNGER PAC™  
STANDARD

**WASTECORP.COM**

HPE 1141 Simplex

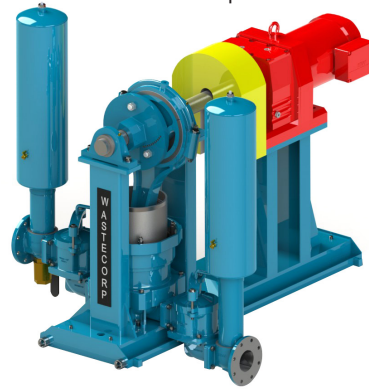

HPE 1142 Duplex

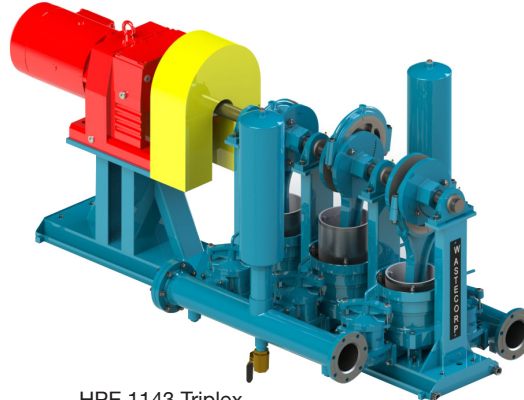
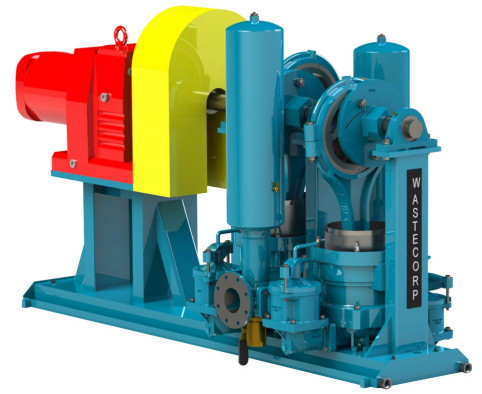

HPE 1143 Triplex

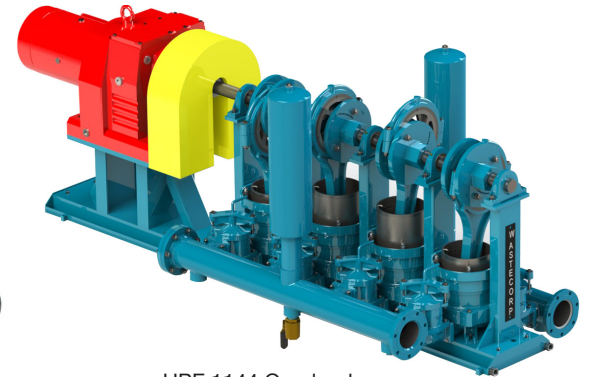

HPE 1144 Quadruplex

**THICKENED SLUDGE. PRIMARY SEWAGE.  
THE SLUDGE MASTER PUMPS IT ALL.**

The severe duty HPE Series is specified for municipal and industrial sewage, sludge, food processing waste and much more. This pump series is available with single ball valve or dual ball valve configurations for pumping higher percentages of solids.

With the HPE your facility can pump up to 556 GPM. Wastecorp also offers leak resistant packing systems, guided plunger assemblies for less component wear and pressure switches to help protect your pump.

General Specifications	Simplex HPE 1141	Duplex HPE 1142	Triplex HPE 1143	Quadruplex HPE 1144
Number of plungers	1	2	3	4
Plunger dia. (in)	11	11	11	11
Air chambers	(2) 9"x30"			
Flanged connections	4" ANSI 125 #	4" ANSI 125 #	6" ANSI 150 #	6" ANSI 150 #
Number of pin positions	11			
RPM Speeds	50			
Max. stroke length (in)	7.25			
Max. rec. suction lift (ft)	20			
Max. total head (ft)	170	170	130	95
Max. capacity (GPM)	142	280	418	556
Eccentric dia. (in)	12			
Shaft tensile strength (PSI)	160,000			

**SLUDGE MASTER<sup>®</sup>**  
SEVERE DUTY PLUNGER PUMPS  
**HPE SERIES**



Pump Component	Standard Material	Optional Material
<b>MAINSHAFT</b>	A4140/4142 High-Strength Alloy Steel	
<b>ECCENTRIC</b>	ASTM A48, Class 35 Grey Iron	
<b>LUBRICATION</b>	Manual Sight Feed Oiler, 5 oz	a) Automatic ball-type oiler with needle valve (5 oz), b) Electric Solenoid Oiler, c) Mechanical Force Feed Lubricator
<b>DRIVEN/DRIVE FLANGES</b>	ASTM A48, Class 35 Grey Iron	
<b>AIR CHAMBER</b>	A53 Seamless Steel Pipe, Anodized/Galvanized with ¼" brass air release valve/petcock	304 or 316 Stainless Steel
<b>SHEAR PIN</b>	Fabricated Cold Rolled Steel	
<b>CONNECTING ROD</b>	ASTM A536 Grade 65-45-12 Ductile Iron	
<b>ECCENTRIC BEARING LINER</b>	Replaceable, Bronze SAE 660	
<b>BUSHING, WRIST PIN</b>	SAE 941 Oil-Lite Bronze	
<b>WRIST PIN</b>	A4140/4142 High-Strength Alloy Steel	
<b>VALVE SEAT</b>	ASTM A48, Class 35 Grey Iron	Bronze Alloy, 316 Stainless Steel
<b>BALL VALVE</b>	5-1/8" Urethane Rubber with Centralized Iron Core	
<b>PLUNGER</b>	ASTM A48, Class 35 Grey Iron	
<b>PUMP BODY</b>	ASTM A536 Grade 65-45-12 Ductile Iron	Coatings Available: a) Chrome Oxide, b) Aluminum Oxide, c) Tungsten Carbide, d) Hastelloy C, e) Stainless Steel
<b>STUFFING BOX</b>	ASTM A536 Grade 65-45-12 Ductile Iron	
<b>GLAND</b>	ASTM A48, Class 35 Grey Iron	
<b>FLANGE CONNECTION</b>	4" ANSI 125 lb (Simplex and Duplex Pumps) 6" ANSI 150 lb (Triplex and Quad Pumps)	
<b>PACKING</b>	½" sq. Kevlar Braided with Poly-urethane seal	a) Graphite Rings Only, b) Chevron Rings Only, c) Combo (Graphite/Chevron), d) Plunger Pac (Chevron, Teflon and Poly-urethane seal)
<b>PUMP BASE</b>	Fabricated heavy-duty steel channel and tube base plate and pedestals with drip gutters and 1" drain connections	Floor Base Frame
<b>DRIVE ARRANGEMENT</b>	Electric Constant Speed, Vertical Gear Reducer coupled to pump's mainshaft, Max. Output Speed: 50 RPM	

# SLUDGE MASTER<sup>®</sup>

SEVERE DUTY PLUNGER PUMPS

## HPE SERIES



### PERFORMANCE CURVES

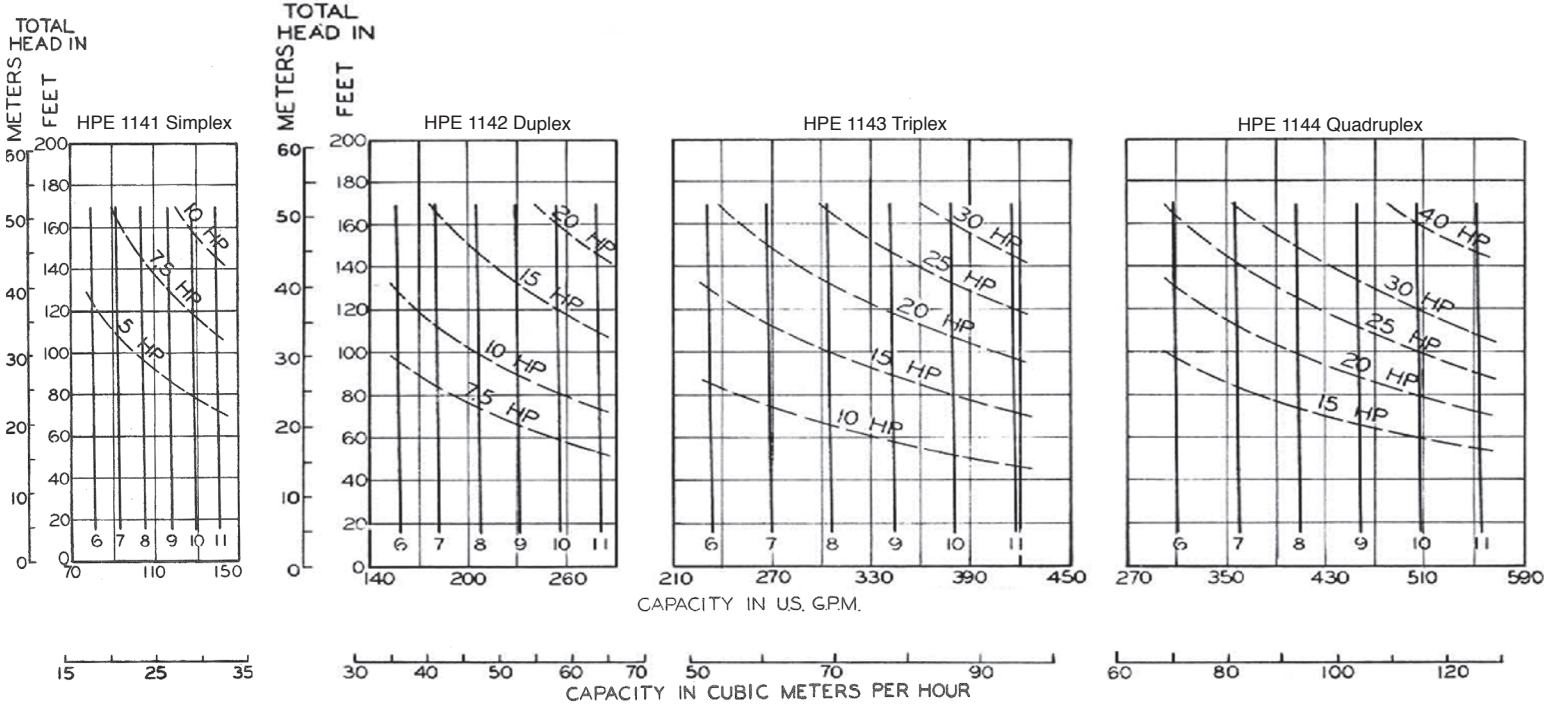

PIN POS.	STROKE LENGTH INCHES	STROKE LENGTH CM
6	4.125	10.5
7	4.750	12.1
8	5.375	13.7
9	6.000	15.2
10	6.625	16.8
11	7.250	18.4

### Cross Section Assembly

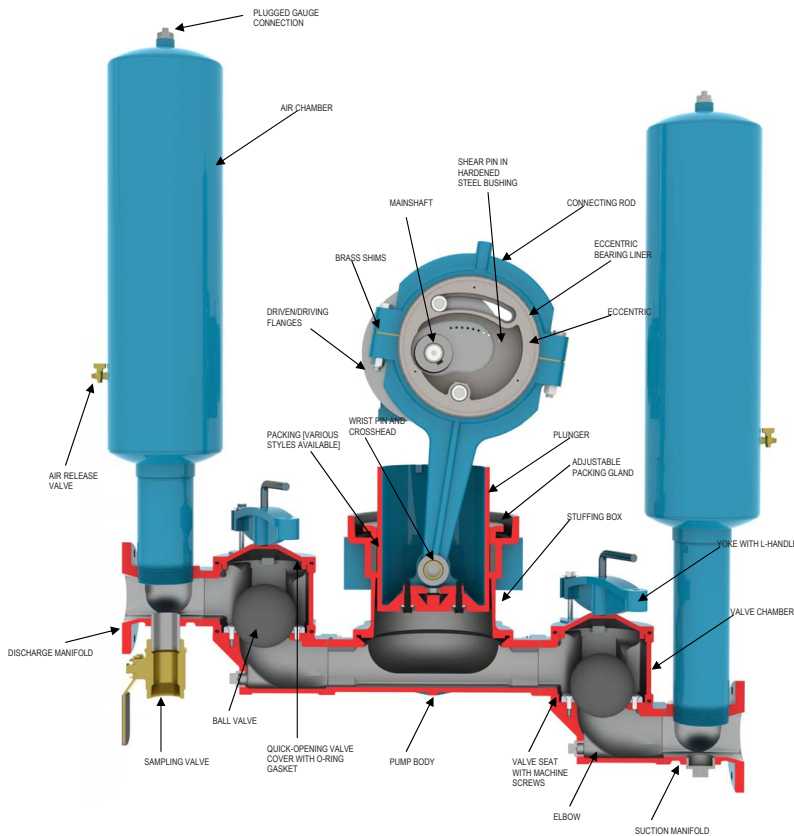

# SLUDGE MASTER<sup>®</sup>

SEVERE DUTY PLUNGER PUMPS

## HPE SERIES



### DIMENSIONAL DRAWINGS

HPE 1141 Simplex

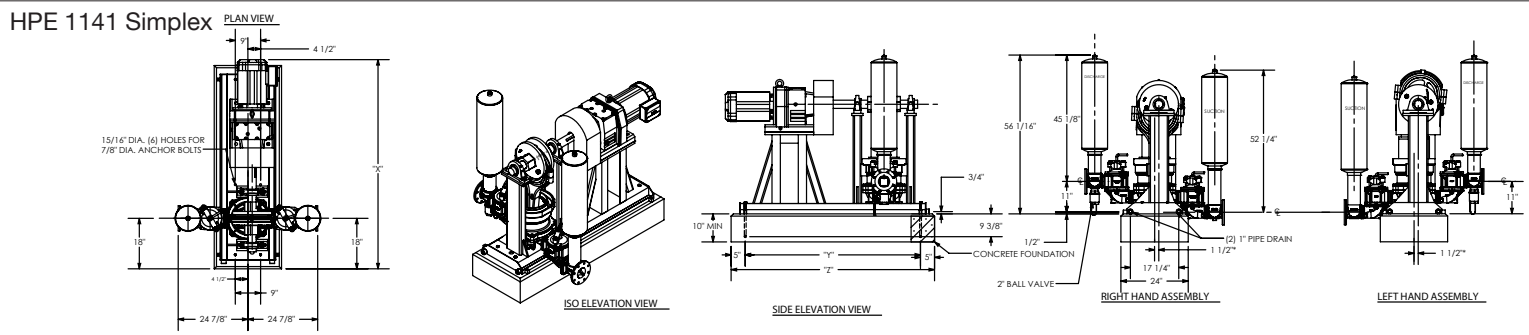

HPE 1142 Duplex

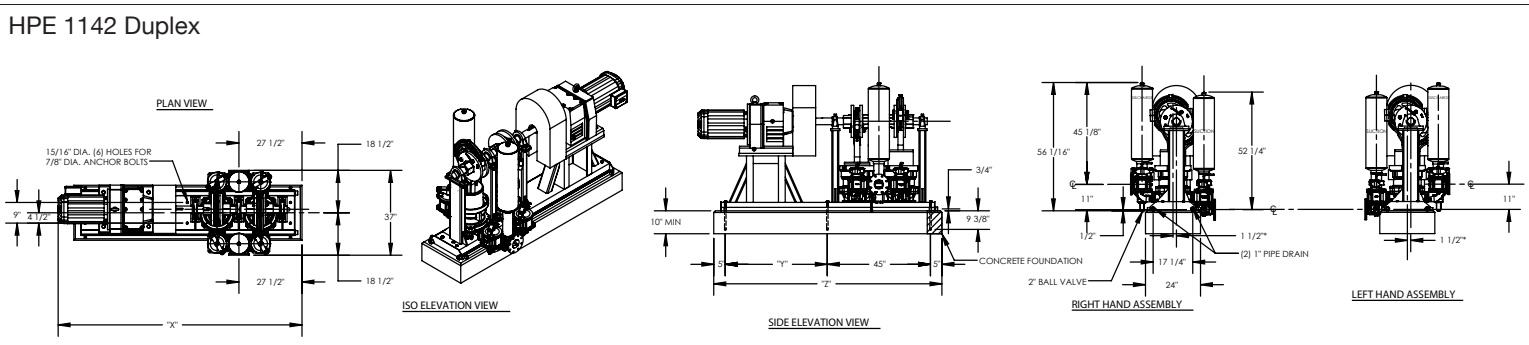

HPE 1143 Triplex

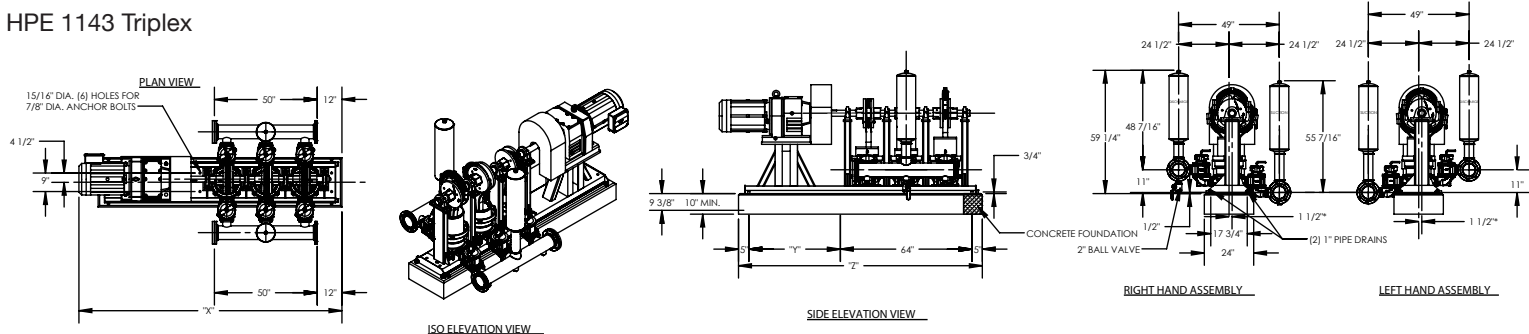

HPE 1144 Quadruplex

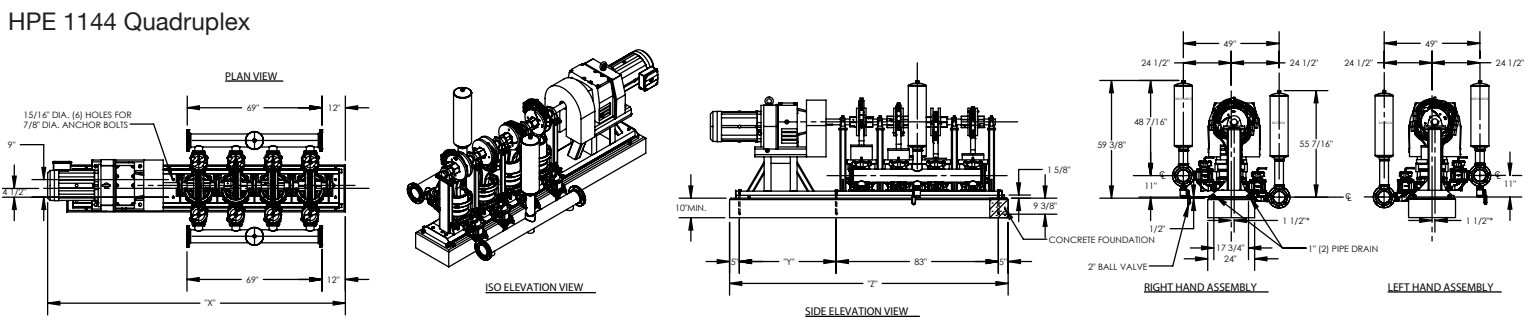

Wastecorp Pumps USA  
 P.O. Box 70  
 Grand Island, New York 14072 | USA  
 Tel: 888.829.2783 | Fax: 888-883-3320  
 sales@wastecorp.com

Wastecorp Pumps Inc.  
 50 Shorncliffe Road  
 Toronto, Ontario M8Z 5K1 | Canada  
 Tel: 416.233.3000 | Fax: 416.233.2300  
 info@wastecorp.com