

Power and Performance

2EFA - EC Series

Heavy Duty Diaphragm Pumps

FEATURES

- 2" Connection size
- Pump up to 33 GPM
- Transfer spherical solids up to 2" or 50% by volume
- Pressure relief valve standard on all models
- Pump up to 25' vertical
- Heavy duty diaphragm
- 2HP electric motors



When considering your outdoor fluid handling application, make sure you have the right equipment to get tough fluids moving along smoothly. The right pump should have advanced components and materials to see your application through from start to finish. Technology is getting smarter and so are the next generation diaphragm pumps from Wastecorp.

Performance

| | |
|---------------------|-------------------------|
| Max. capacity | 33 GPM |
| Max. suction lift | 15' vertical |
| Max. discharge head | 25' vertical |
| Solids handling | 2" dia or 50% by volume |

Pump Models

| Part # | Description |
|----------|---|
| 66099-00 | Mud Sucker 2EFA - EC w/ 2HP Single Phase Volts: 115 / 230 Amps: 20 / 10 |
| 66099-10 | Mud Sucker 2EFA - EC w/ 2HP Three Phase 460volt |
| 65740-02 | Mud Sucker 2EFA Dolly Kit |

Pump and Motor Specifications

| | |
|--------------------------------------|---|
| Suction inlet/outlet size | 2"x2" |
| Max. liquid temperature | 140°F (60°C) continuous |
| Pump body casing | Marine grade aluminum (ASTM A356, Class 30) |
| Diaphragm | Neoprene |
| Flapper valves | Fabric reinforced Buna-N (viton optional) |
| Gearbox | Cast aluminum housing with heat treated gears |
| Hardware | Zinc coated |
| Approximate Weight | 100 lbs |
| Rod end bearing body | Cast iron, protective coated for corrosion resistance |
| Ball bearing | Sintered steel, heat treated, oil impregnated |
| Ultimate radial static load capacity | 9,000 Lbs |
| Approximate Pump Weight | 100 Lbs |





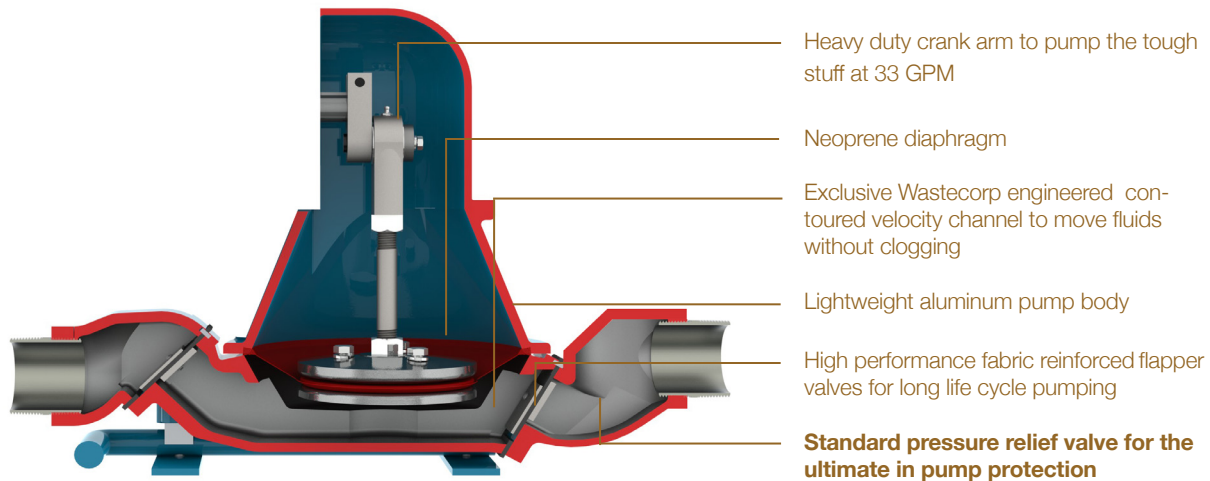









* Consult factory if fluid temperature exceeds 140°F

Mud Sucker® Diaphragm Pumps



Manufactured in North America. Country/region specific models are available worldwide.

Enhanced pump out productivity with your Mud Sucker diaphragm pump can be as easy as adding a few simple accessories. So if you need to suck up dirt and debris, need a mess free pump out, or have a heavier duty dewatering application, the right accessories can enhance your fluid handling one step further.

| Part no. | Description | Part no. | Description |
|--|--|--|---|
|  60462-00 | Camlock fitting 2" alum. male adapter MNPT |  65740-02 | Wheel mount kit with handles (Inline) |
|  62974-00 | 3-way brass valve w/ aluminum camlocks |  62301-00 | SEW Movimot 24V key pad speed control |
|  66143-00 | Starter Control Panel w/NEMA 4 / 12 |  Various | Waste containment system with tank, hoses, trailer and pump |
|  62742-00 | Air chamber assembly, Pulsation dampening |  99921-99 | Medium duty wagon kit |
|  60718-00 | Non-collapsible EPDM hose 2"x20'. Camlocks included |  Various | Wet section coatings for specific applications |
|  51333-10 | Discharge hose, lay flat (brown) 2"x50'. Camlocks included |  The Gulper™ Suction tool No more bending | The Gulper™ Suction tool No more bending |
|  34383-00 | Stainer, sq. hole (solids) 2" FNPT |  61387-00 | Universal sewer adapter assembly |
|  60536-00 | Clear swing check valve 2" FPTxFPT | | |

Mud Sucker® Diaphragm Pumps

Toll-Free: 1.888.829.2783 Email: info@wastecorp.com



OEM Manufacturer

Mud Sucker 3EFA Series pumps are specified for the following industries and applications: General wastewater pumping, septic pump, construction pump, Federal and military, agricultural, aquaculture farming, farms, food processing, oil, gas, shale, select chemicals, pulp and paper mills, marine pumping applications, waste oil pumping, landfills, dewatering, biodiesel production, public works and others. Mention your application to your technical support representative at the time of order. Before operating your diaphragm pump, read, understand and follow all instructions in the manual and on the pump. Specifications and programs are accurate at the time of publication but subject to change without notice. Images may not reflect dealer inventory and/or unit specifications. Wastecorp, Mud Sucker and globes are trademarks of Wastecorp, WPCI Environmental Brands. No reproduction of this document without permission. © Wastecorp.

DIMENSIONS

STATIONARY

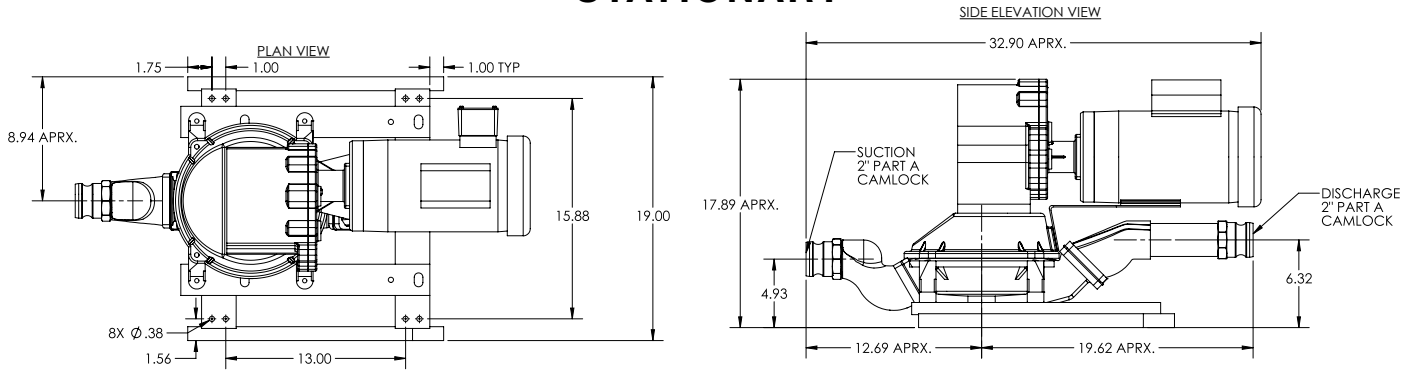

STATIONARY WITH ROLL CAGE

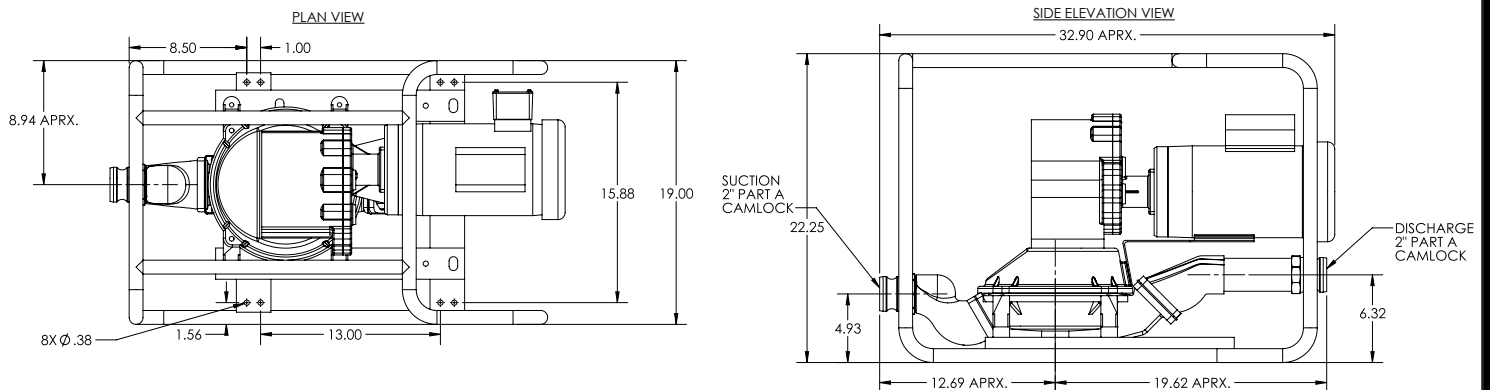

WHEEL MOUNT

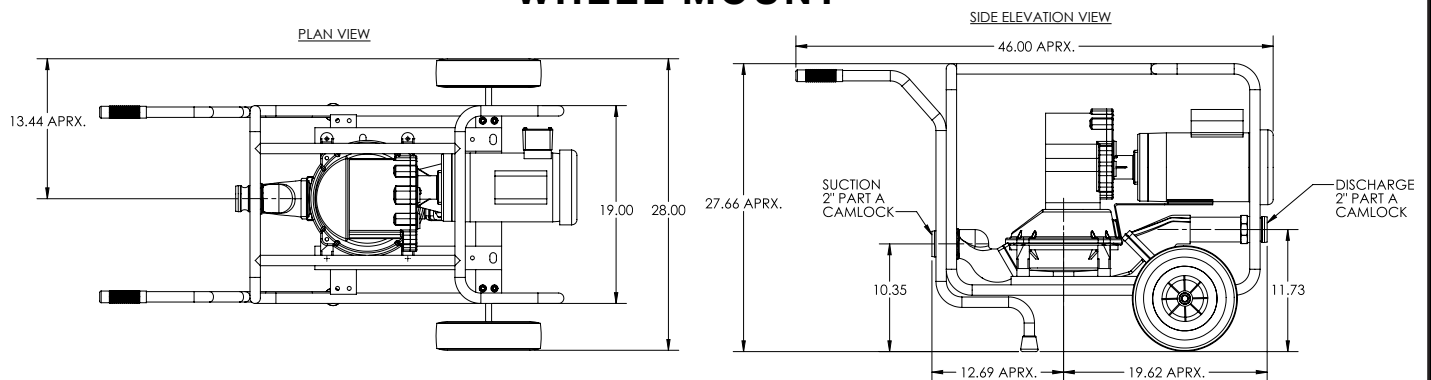

Mud Sucker® Diaphragm Pumps

Toll-Free: 1.888.829.2783 Email: info@wastecorp.com



OEM Manufacturer

Mud Sucker 3EFA Series pumps are specified for the following industries and applications: General wastewater pumping, septic pump, construction pump, Federal and military, agricultural, aquaculture farming, farms, food processing, oil, gas, shale, select chemicals, pulp and paper mills, marine pumping applications, waste oil pumping, landfills, dewatering, biodiesel production, public works and others. Mention your application to your technical support representative at the time of order. Before operating your diaphragm pump, read, understand and follow all instructions in the manual and on the pump. Specifications and programs are accurate at the time of publication but subject to change without notice. Images may not reflect dealer inventory and/or unit specifications. Wastecorp, Mud Sucker and globes are trademarks of Wastecorp, WPCI Environmental Brands. No reproduction of this document without permission. © Wastecorp.