

Mud Sucker®  
Diaphragm Pumps

## 2FACB-EC Series

Multipurpose  
Diaphragm Pumps

1.5FACB-EC™

2FACB-EC™

### FEATURES

Pump up to 20 GPM

Runs dry without damage

Select from 1½" or 2"  
connections

Transfer spherical solids up to  
1.5" or 50% by volume

Pump weighs under 80 lbs

7" heavy duty diaphragm

Light weight aluminum pump  
body

  
**WASTECORP.**  
Pumps®

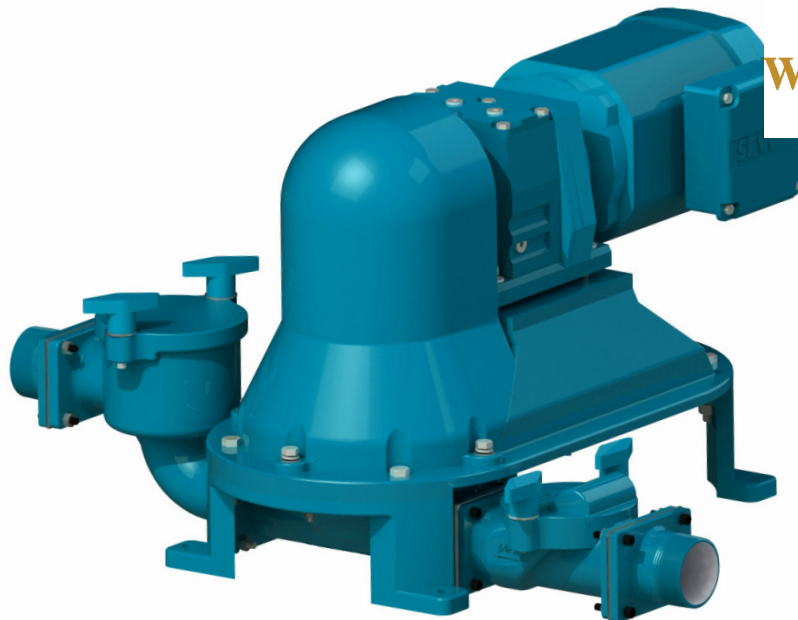

## PERFORMANCE & RELIABILITY

The Mud Sucker 2FACB-EC is a high performance, positive displacement diaphragm pump. The 2FACB-EC can run dry without damage.

This pump is designed to pump over 2000 types of fluids ranging from general wastewater and septic pumping to waste oil, vegetable oil, used motor oil, and food processing waste. The 2FACB-EC electric diaphragm pump sees a lot of applications. It's rated as one of the top multipurpose 2" electric pumps

The 2FACB-EC includes an enhanced velocity channel to move fluids and higher tensile strength components.

Make Pumping Tough Fluids Easier

Multipurpose Electric Diaphragm Pumps

### Meet Mud Sucker 2FACB-EC Series

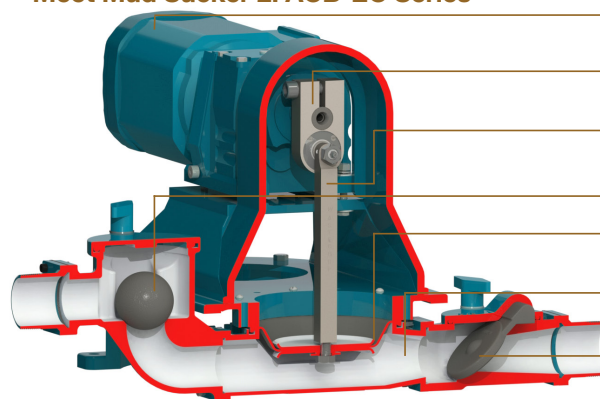

Premium Siemens®, SEW Eurodrive®  
single or three phase drive system

Heavy duty crank arm to pump the tough  
stuff at 20 GPM (max)

Heavy duty pump rod design ensures  
consistent flow and performance

Discharge Check Valve

7" diaphragm

Exclusive Wastecorp engineered velocity  
channel to move fluids without clogging

Suction Check Valve

MUD SUCKER® DIAPHRAGM PUMPS THE PUMP WITH ATTITUDE.

[wastecorp.com](http://wastecorp.com)

Patent pending electric diaphragm pump design.

Rev: November 18 2019

## Mud Sucker® Diaphragm Pumps









### Performance Range

|                     |  |
|---------------------|--|
| Max. Capacity       | 20 GPM   |
| Max. Suction Lift   | 20' vertical or 75' horizontal (with foot valve) |
| Max. Discharge Head | 50' vertical or 22 psi max.                      |
| Solids Handling     | 1½" dia or 50% by volume                         |

### Pump and Motor Specifications

|                              |  |
|------------------------------|--|
| Suction Inlet/Outlet Size    | 1½" or 2" MNPT (optional male camlock) |
| Max. Liquid Temperature      | 140°F (60°C) continuous                |
| Pump Body Casing             | Aluminum A356, heat treated            |
| Diaphragm                    | 7" OD fabric reinforced                |
| Check Valves                 | Neoprene                               |
| Crankarm & Pump Rod Assembly | AISI 12L14 carbon steel                |
| Gear Reducer                 | Siemens or SEW Eurodrive               |
| Max. Pump Operating Speed    | 70 RPM                                 |

## ATTACHMENTS

| Part no.   | Description   |
|--|---|
|  64093-02  | <b>RECOMMENDED!</b><br>Pressure sensor assembly                                   |
|  65039-00 | Basic spare parts kit (diaphragm and flappers)                                    |
|  60444-00 | Comprehensive spare parts kit (diaphragm, flappers gaskets, weights and hardware) |
|  60718-00 | Non-collapsible EPDM hose 2"x20'. Camlocks included                               |
|  51333-10 | Discharge hose, lay flat (brown) 2"x50'. Camlocks included                        |
|  34383-00 | Stainer, sq. hole (solids) 2" FNPT  |
|  61387-00 | Universal sewer adapter assembly  |
|  60536-00 | Clear swing check valve 2" FPTxFTPT   |
|  60462-00 | Camlock fitting 2" alum. male adapter MNPT  |
|  61315-00 | Wheel mount kit with handles  |
|  62538-00 | Mobility package (stationary) lifting bars  |

### Mud Sucker® Diaphragm Pumps

Toll-Free: 1.888.829.2783 Email: info@wastecorp.com





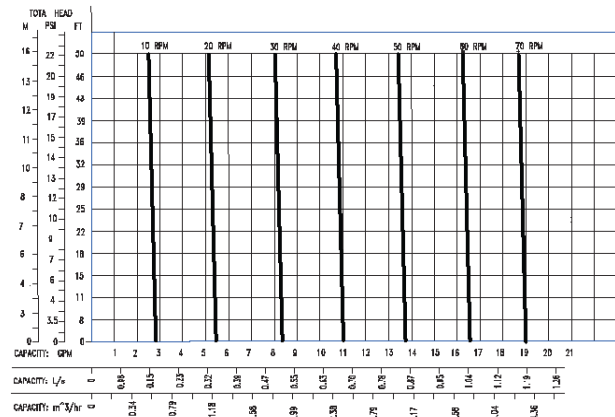

### Motor Specifications

| Description                          | Part No. | Motor Option                 |
|--------------------------------------|----------|------------------------------|
| Standard motor Three Phase (TEFC)    | 66130-00 | 1 hp, 1800 RPM/3/60/230/460V |
| Single Phase (TEFC)                  | 66130-10 | 1 hp, 1800 RPM/1/60/115/230V |
| Explosion Proof (Three Phase), TEXP  | 66130-05 | 1 hp, 1800 RPM/3/60/230/460V |
| Explosion Proof (Single Phase), TEXP | 66130-15 | 1 hp, 1800 RPM/1/60/115/230V |

Also available with 12 V DC Power, 24V DC, gas, diesel, air or hydraulic drives. Optional in line piping configuration also available. Contact factory for optional Hertz/voltages available.

## PERFORMANCE CURVE



| Part no.   | Description   |
|--|---|
|  62742-00 | Air chamber assembly, Pulsation dampening               |
|  Various  | Wet section coatings for specific applications          |
|  62301-00 | SEW Movimot 24V key pad speed control                   |
|  61492-00 | Starter Control Panel w/NEMA 12 protection              |
|  61491-00 | Transformer start/estop, w/ Nema 12 overload protection |
|  62974-00 | 3-way brass valve w/ aluminum camlocks                  |
|  60506-00 | The Gulper™ Suction tool. No more bending               |



**WASTECORP. OEM Manufacturer Pumps®**

Mud Sucker 2FACB Series pumps are specified for marine pumping applications, waste oil pumping, leachate recovery, dewatering, biodiesel production and many other applications. Mention your application to your technical support representative at the time of order. Before operating your diaphragm pump, read, understand and follow all instructions in the manual and on the pump. Specifications and programs are accurate at the time of publication but subject to change without notice. Images may not reflect dealer inventory and/or unit specifications. Wastecorp, Mud Sucker and globes are trademarks of Wastecorp, WPI. No reproduction of this document without permission. © Wastecorp 2017. Electric diaphragm pump manufacturer.

# DIMENSIONAL DRAWING

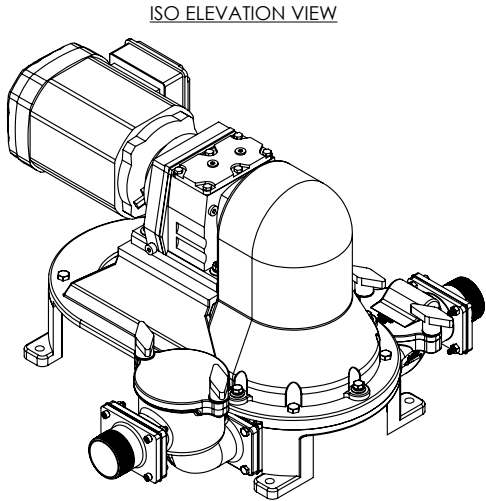

ISO ELEVATION VIEW

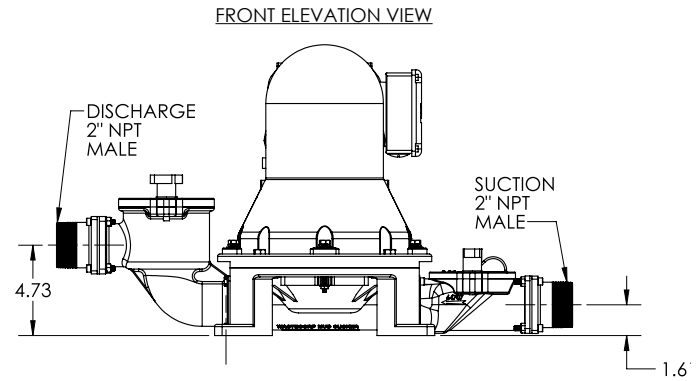
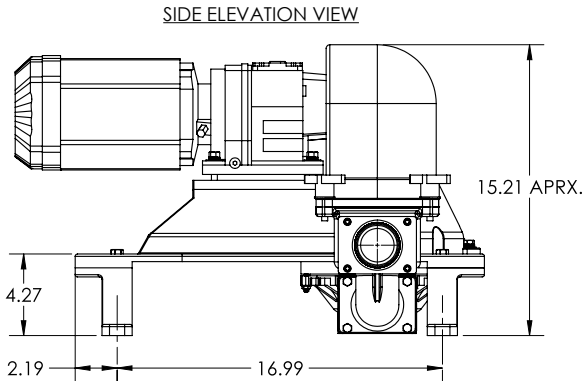
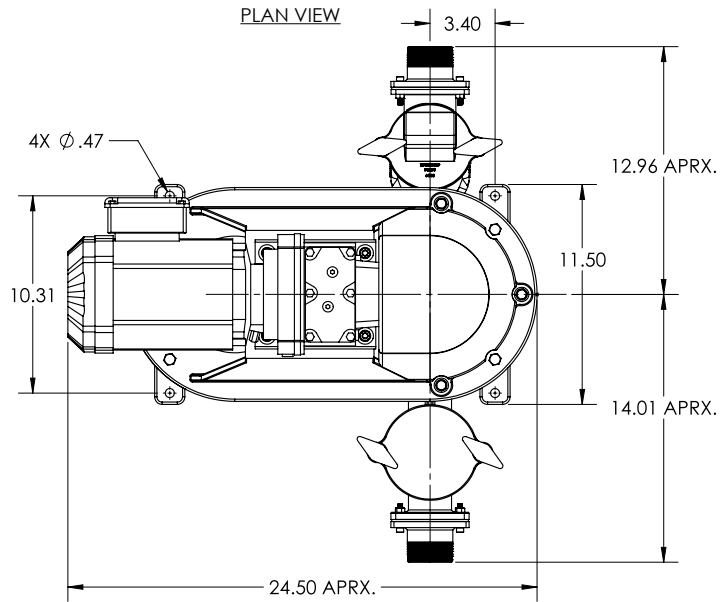

NOTE: NOT FOR CONSTRUCTION UNLESS CERTIFIED

## Mud Sucker® Diaphragm Pumps

Toll-Free: 1.888.829.2783 Email: [info@wastecorp.com](mailto:info@wastecorp.com)



**WASTECORP. OEM Manufacturer**  
**Pumps®**

Mud Sucker 2FACB Series pumps are specified for marine pumping applications, waste oil pumping, leachate recovery, dewatering, biodiesel production and many other applications. Mention your application to your technical support representative at the time of order. Before operating your diaphragm pump, read, understand and follow all instructions in the manual and on the pump. Specifications and programs are accurate at the time of publication but subject to change without notice. Images may not reflect dealer inventory and/or unit specifications. Wastecorp, Mud Sucker and globes are trademarks of Wastecorp, WPI. No reproduction of this document without permission. © Wastecorp 2017. Electric diaphragm pump manufacturer.