

# Power and Performance

## 3EFA - EC Series

### Heavy Duty Diaphragm Pumps

#### FEATURES

- ..... 3" Connection size
- ..... Pump up to 50 GPM
- ..... Transfer spherical solids up to 2" or 50% by volume
- ..... Pressure relief valve standard on all models
- ..... Pump up to 25' vertical
- ..... Heavy duty diaphragm
- ..... 2HP electric motors



When considering your outdoor fluid handling application, make sure you have the right equipment to get tough fluids moving along smoothly. The right pump should have advanced components and materials to see your application through from start to finish. Technology is getting smarter and so are the next generation diaphragm pumps from Wastecorp.

#### Performance

Max. capacity	50 GPM
Max. suction lift	25' vertical
Max. discharge head	25' vertical
Solids handling	2" dia or 50% by volume

#### Pump Models

Part #	Description
66051-30	Mud Sucker 3EFA - EC w/ 2HP Single Phase Volts: 115 / 230 Amps: 20 / 10
66051-40	Mud Sucker 3EFA - EC with 2HP Three Phase 460volt
65740-02	Mud Sucker 3EFA Dolly Kit

#### Pump and Motor Specifications

Suction inlet/outlet size	3"x3"
Max. liquid temperature	140°F (60°C) continuous
Pump body casing	Marine grade aluminum (ASTM A356, Class 30)
Diaphragm	Neoprene
Flapper valves	Fabric reinforced Buna-N (viton optional)
Gearbox	Cast aluminum housing with heat treated gears
Hardware	Zinc coated
Rod end bearing body	Cast iron, protective coated for corrosion resistance
Ball bearing	Sintered steel, heat treated, oil impregnated
Ultimate radial static load capacity	9,000 Lbs
Approximate Pump Weight	156 Lbs

\* Consult factory if fluid temperature exceeds 140°F



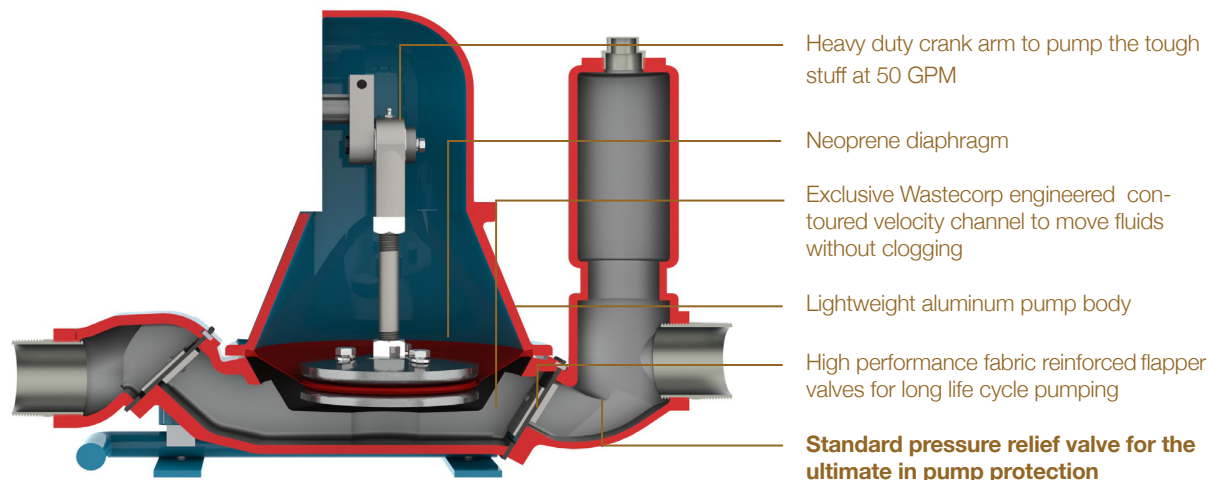













## Mud Sucker® Diaphragm Pumps



Manufactured in North America. Country/region specific models are available worldwide.

# ATTACHMENTS

Enhanced pump out productivity with your Mud Sucker diaphragm pump can be as easy as adding a few simple accessories. So if you need to suck up dirt and debris, need a mess free pump out, or have a heavier duty dewatering application, the right accessories can enhance your fluid handling one step further.

Part no.	Description	Part no.	Description
 60466-00	Camlock fitting 3" alum. male adapter MNPT	 61316-00	Wheel mount kit with handles (inline)
 62975-00	3-way brass valve w/ aluminum camlocks (discharge only)	 62732-00	Wheel mount kit with handles (standard)
 69999-99	Roll Cage	 61292-00	Professional Wagon kit, 16" pneumatic tires
 61605-00	Air chamber (discharge side). Pulsation dampening	 99921-99	Medium duty wagon kit
 60723-00	Non-collapsible EPDM hose 3"x20'. Camlocks included	 Various	Wet section coatings for specific applications
 51334-10	Discharge hose, lay flat (brown) 3"x50'. Camlocks included	 The Gulper™ Suction tool No more bending	The Gulper™ Suction tool No more bending
 31345-00	Stainer, round hole (solids) 3" FNPT	 60581-00	Round hole strainer for non-clog performance
 61245-00	Clear swing check valve 3" FPTxFPT	 Various	Waste containment system with tank, hoses, trailer and pump
 66143-00	Starter Control Panel w/NEMA 4 / 12		

## Mud Sucker® Diaphragm Pumps

Toll-Free: 1.888.829.2783 Email: [info@wastecorp.com](mailto:info@wastecorp.com)



**OEM Manufacturer**

Mud Sucker 3EFA Series pumps are specified for the following industries and applications: General wastewater pumping, septic pump, construction pump, Federal and military, agricultural, aquaculture farming, farms, food processing, oil, gas, shale, select chemicals, pulp and paper mills, marine pumping applications, waste oil pumping, landfills, dewatering, biodiesel production, public works and others. Mention your application to your technical support representative at the time of order. Before operating your diaphragm pump, read, understand and follow all instructions in the manual and on the pump. Specifications and programs are accurate at the time of publication but subject to change without notice. Images may not reflect dealer inventory and/or unit specifications. Wastecorp, Mud Sucker and globes are trademarks of Wastecorp, WPCI Environmental Brands. No reproduction of this document without permission. © Wastecorp.

# DIMENSIONS

## STATIONARY

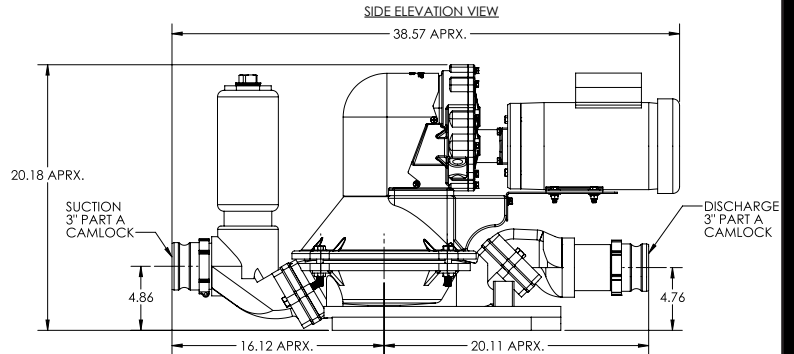
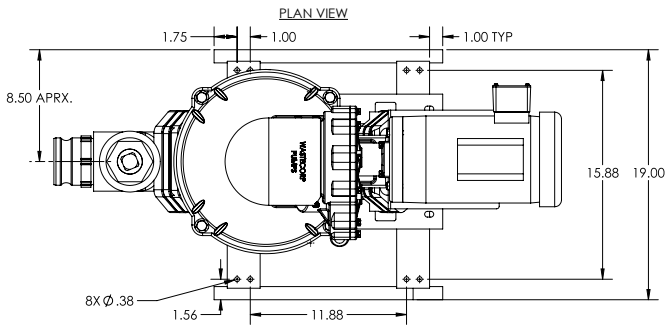

## STATIONARY WITH ROLL CAGE

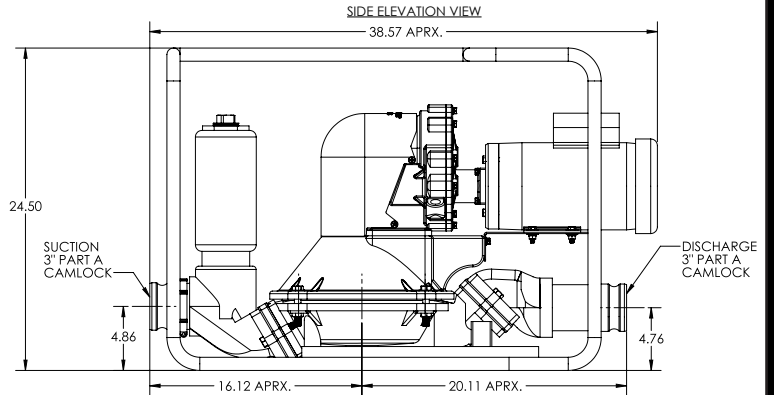
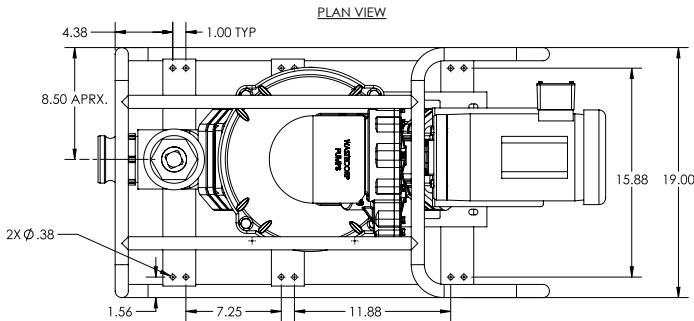

## WHEEL MOUNT

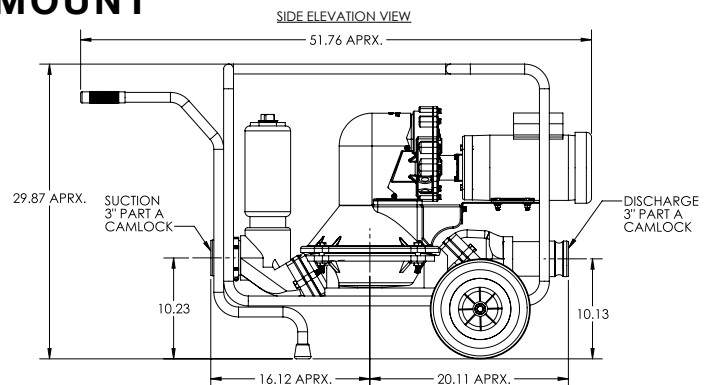
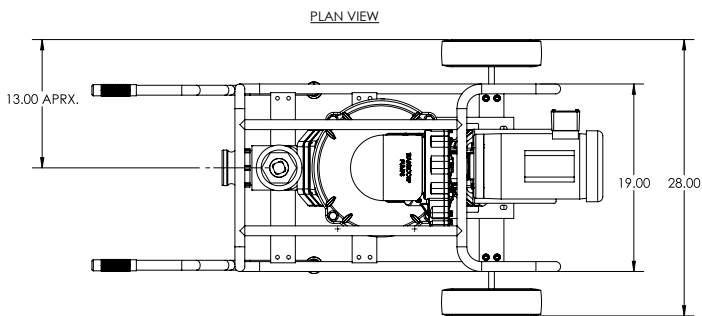

### Mud Sucker® Diaphragm Pumps

Toll-Free: 1.888.829.2783 Email: [info@wastecorp.com](mailto:info@wastecorp.com)



**OEM Manufacturer**

Mud Sucker 3EFA Series pumps are specified for the following industries and applications: General wastewater pumping, septic pump, construction pump, Federal and military, agricultural, aquaculture farming, farms, food processing, oil, gas, shale, select chemicals, pulp and paper mills, marine pumping applications, waste oil pumping, landfills, dewatering, biodiesel production, public works and others. Mention your application to your technical support representative at the time of order. Before operating your diaphragm pump, read, understand and follow all instructions in the manual and on the pump. Specifications and programs are accurate at the time of publication but subject to change without notice. Images may not reflect dealer inventory and/or unit specifications. Wastecorp, Mud Sucker and globes are trademarks of Wastecorp, WPCI Environmental Brands. No reproduction of this document without permission. © Wastecorp.