

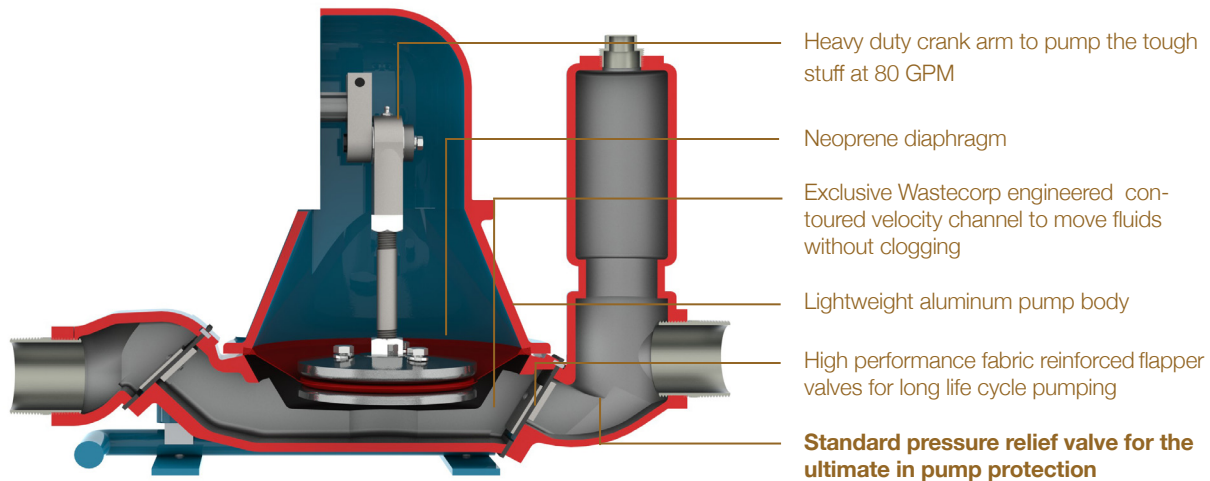

## Mud Sucker® Diaphragm Pumps



Heavy duty crank arm to pump the tough stuff at 80 GPM

Neoprene diaphragm

Exclusive Wastecorp engineered contoured velocity channel to move fluids without clogging

Lightweight aluminum pump body

















High performance fabric reinforced flapper valves for long life cycle pumping

**Standard pressure relief valve for the ultimate in pump protection**

Manufactured in North America. Country/region specific models are available worldwide.

# ATTACHMENTS

Enhanced pump out productivity with your Mud Sucker diaphragm pump can be as easy as adding a few simple accessories. So if you need to suck up dirt and debris, need a mess free pump out, or have a heavier duty dewatering application, the right accessories can enhance your fluid handling one step further.

Part no.	Description	Part no.	Description
 60466-00	Camlock fitting 3" alum. male adapter MNPT	 61316-00	Wheel mount kit with handles (inline)
 62975-00	3-way brass valve w/ aluminum camlocks (discharge only)	 62732-00	Wheel mount kit with handles (standard)
 61292-00	Professional Wagon kit, 16" pneumatic tires	 69999-99	Roll Cage
 61605-00	Air chamber (discharge side). Pulsation dampening	 99921-99	Medium duty wagon kit
 60723-00	Non-collapsible EPDM hose 3"x20'. Camlocks included	 Various	Wet section coatings for specific applications
 51334-10	Discharge hose, lay flat (brown) 3"x50'. Camlocks included	 The Gulper™ Suction tool No more bending	The Gulper™ Suction tool No more bending
 31345-00	Stainer, round hole (solids) 3" FNPT	 60581-00	Round hole strainer for non-clog performance
 61245-00	Clear swing check valve 3" FPTxFPT	 Various	Waste containment system with tank, hoses, trailer and pump

## Mud Sucker® Diaphragm Pumps

Toll-Free: 1.888.829.2783 Email: [info@wastecorp.com](mailto:info@wastecorp.com)



**OEM Manufacturer**

Mud Sucker 3EFA Series pumps are specified for the following industries and applications: General wastewater pumping, septic pump, construction pump, Federal and military, agricultural, aquaculture farming, farms, food processing, oil, gas, shale, select chemicals, pulp and paper mills, marine pumping applications, waste oil pumping, landfills, dewatering, biodiesel production, public works and others. Mention your application to your technical support representative at the time of order. Before operating your diaphragm pump, read, understand and follow all instructions in the manual and on the pump. Specifications and programs are accurate at the time of publication but subject to change without notice. Images may not reflect dealer inventory and/or unit specifications. Wastecorp, Mud Sucker and globes are trademarks of Wastecorp, WPCI Environmental Brands. No reproduction of this document without permission. © Wastecorp.

# DIMENSIONS

## STATIONARY WITH ROLL CAGE

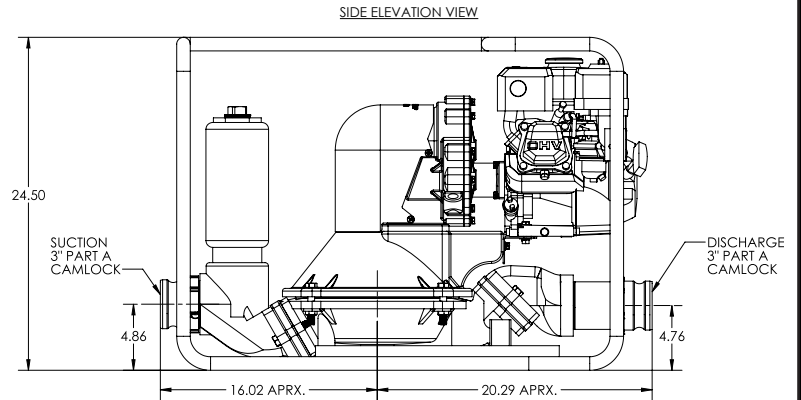
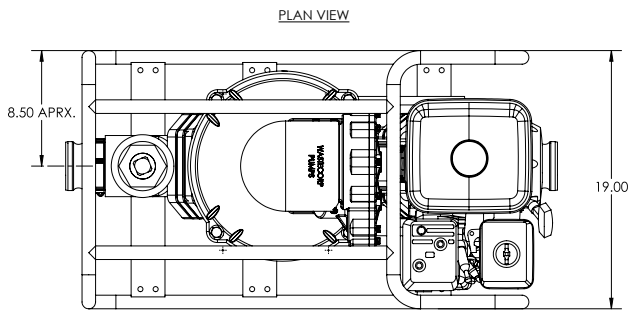

## WHEEL MOUNT

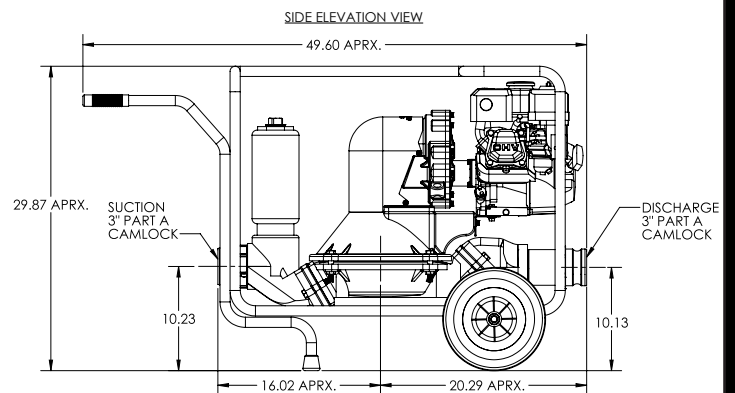
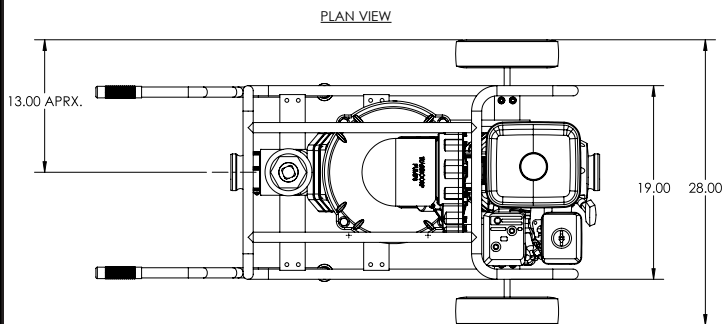

### Mud Sucker® Diaphragm Pumps

Toll-Free: 1.888.829.2783 Email: [info@wastecorp.com](mailto:info@wastecorp.com)



OEM Manufacturer

Mud Sucker 3EFA Series pumps are specified for the following industries and applications: General wastewater pumping, septic pump, construction pump, Federal and military, agricultural, aquaculture farming, farms, food processing, oil, gas, shale, select chemicals, pulp and paper mills, marine pumping applications, waste oil pumping, landfills, dewatering, biodiesel production, public works and others. Mention your application to your technical support representative at the time of order. Before operating your diaphragm pump, read, understand and follow all instructions in the manual and on the pump. Specifications and programs are accurate at the time of publication but subject to change without notice. Images may not reflect dealer inventory and/or unit specifications. Wastecorp, Mud Sucker and globes are trademarks of Wastecorp, WPCI Environmental Brands. No reproduction of this document without permission. © Wastecorp.