

MUD SUCKER®
DIAPHRAGM PUMPS

DD-EC Series

DOUBLE
DIAPHRAGM
PUMPS

3FA-ECDD™

FEATURES

Pump up to 160 GPM

Transfer solids up to 2¼" or
50% by volume

Aluminum pump body

13" diaphragms (x2)

High performance fabric rein-
forced Viton® flapper valves



WASTECORP.
Pumps®

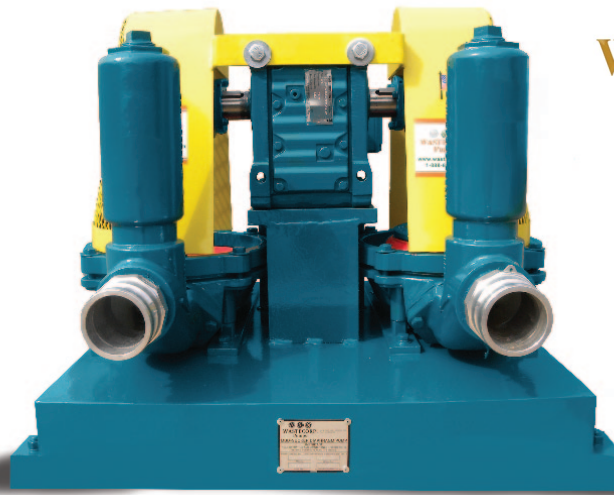

DOUBLE THE POWER, DOUBLE THE ATTITUDE. DOUBLE DIAPHRAGM PUMPS WITH AN EDGE.

The Mud Sucker double diaphragm pump 3FA-ECDD Series is an unprecedented combination of engineering excellence, premium component selection and powerful pumping performance. With 3" connections and 13" diaphragms you can transfer up to 160 GPM and pump solids up to 2¼". Better yet, you choose from five piping arrangements that we build for your unique fluid handling space - ranging from single suction to double suction configurations. You can also specify components for your specific industry including FDA compliant internals for food processing applications, to oil and gas industry rated flappers and diaphragms that are designed for more viscous fluids and dewatering applications.

Double Diaphragm Pumps Designed for The Long Haul

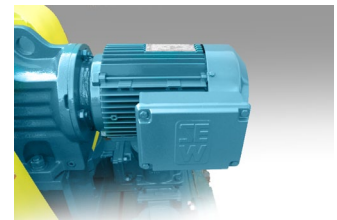
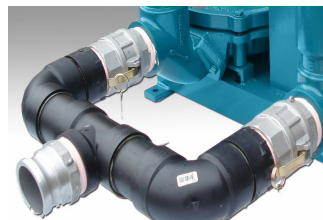
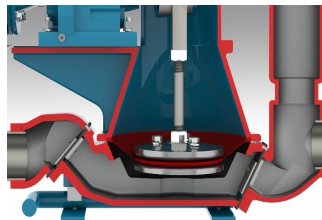

SMARTER PUMP DESIGN

Like all FA Series pumps the industry exclusive contoured velocity channel makes pumping easier, more efficient and consistent

PIPING DESIGNED FOR YOUR PUMP SPACE

Don't settle for someone else's piping design. Get the piping configuration that help you pump more volume, more efficiently.

TOP RATED PUMP DRIVE SYSTEMS

Top rated drive systems available in single phase, three phase and air operated models

WHAT THIS MEANS TO YOU.

Less clogs and more power means you spend less time monitoring your fluid handling application.

The piping arrangement is designed based on your type of fluid and pump house arrangement.

Enhanced performance with motors designed for your pump helps you take advantage of all the Mud Sucker pump can do for you

MUD SUCKER® DIAPHRAGM PUMPS THE PUMP WITH ATTITUDE.

wastecorp.com

Meet The Mud Sucker Double Diaphragm Pump Series

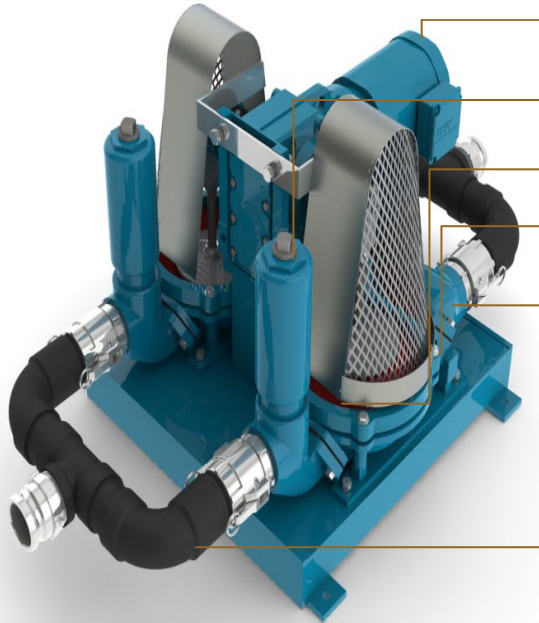

- Premium Siemens®, SEW Eurodrive® or equivalent drive system
- Pulsation dampening air chambers
- 13" Santoprene® diaphragm
- Exclusive Wastecorp engineered velocity channel to move fluids without clogging
- Pump Internals available with industry specific components
- Select from five piping configurations (single suction, single discharge shown)

Mud Sucker electric double diaphragm pumps are manufactured in North America. Country/region specific models are available worldwide.

Performance Range

Max. capacity	160 GPM
Max. Suction lift	25' vertical or 75' horizontal
Max. discharge head	50' vertical or 300' horizontal
Solids handling	2.250" dia. or 50% by volume

Pump Specifications

Suction inlet/outlet size	3"x3"
Max. liquid temperature	220°F (104°C) continuous
Pump body casing	Marine grade aluminum (ASTM A356, Class 30)
Diaphragm	13" dia TPE Santoprene® Severe duty
Flapper valves	Fabric reinforced Buna-N (viton optional)
Gearbox	SEW Eurodrive Model R77 cast iron housing with heat treated gears
Hardware	Zinc coated
Rod end bearing body	Cast iron, sealer coating for corrosion resistance
Ball bearing	Cast iron, sealer coating for corrosion resistance
Ultimate radial static load capacity	9,000 Lbs

Motor Specifications

Description	Part No.	Motor Option
Standard motor (TEFC)	62401-00	5HP; 1800/3/60/230V
Single Phase (TEFC)	62401-10	5HP; 1800/1/60/230V
Explosion Proof (Three phase, TEXP)	62401-20	5HP; 1800/3/60/230V
Explosion Proof (Single phase), TEXP	62401-30	5HP; 1800/1/60/230V

Double Diaphragm Pump Dimensional Drawing

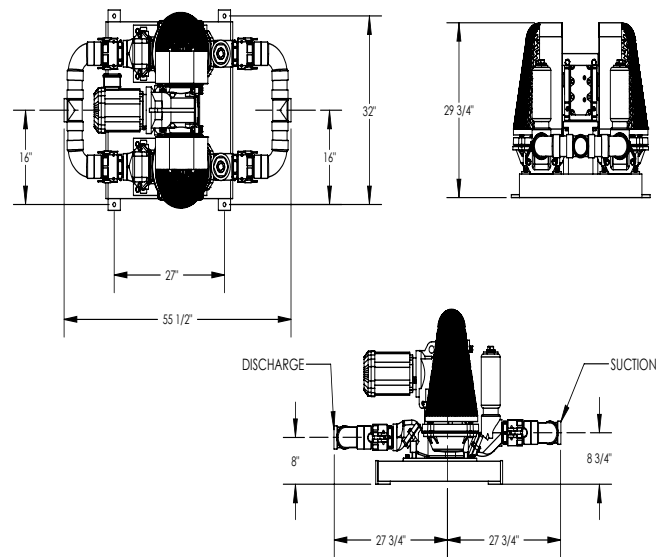

Performance Curve

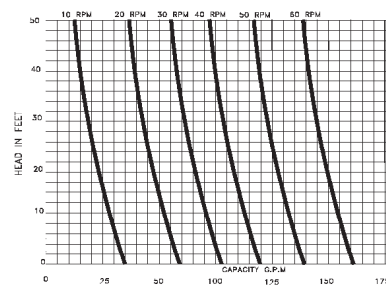

Pump Piping Options

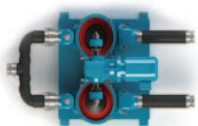

Single suction with double outlet

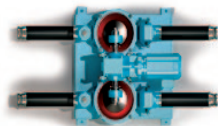

Double suction with double outlet

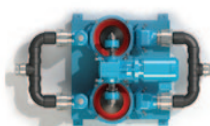

Single suction with single outlet

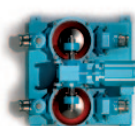



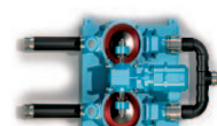









Standard Design



Double suction with single outlet

ACCESSORIES

Part no.	Description	Part no.	Description
 19022-00	Recommended! Pressure relief valve, bronze set at 40 psi	 61292-00	Wheel mount kit with handles
 63198-00 63198-10	Basic spare parts kit (diaphragm and flappers) Viton use 62198-10	 60466-00	Camlock fitting 3" alum. male adapter MNPT
 63199-00 63199-10	Comprehensive spare parts kit (diaphragm, flappers gaskets, weights and hardware). Viton use 62198-10	 63200-00	Air chamber assembly for pulsation dampening
 60723-00	Non-collapsible EPDM hose 3"x20'. Camlocks included	 Various	Wet section coatings for specific applications
 51334-10	Discharge hose, lay flat (brown) 3"x50'. Camlocks included	 62305-00	SEW Movimot 24V key pad speed control
 61245-00	Clear swing check valve 3" FPTxFPT	 61744-00	Starter Control Panel w/ NEMA 12 protection

Mud Sucker® Diaphragm Pumps

Toll-Free: 1.888.829.2783 Email: info@wastecorp.com



Mud Sucker double diaphragm pumps are specified for coal slurry, septic system pumping, dewatering, food processing, FDA compliant pumping systems and most multipurpose pumping applications. Mention your application to your technical support representative at the time of order. Before operating your diaphragm pump, read, understand and follow all instructions in the manual and on the pump. Specifications and programs are accurate at the time of publication but subject to change without notice. Images may not reflect dealer inventory and/or unit specifications. Wastecorp, Mud Sucker and globes are trademarks of Wastecorp, WPCI Environmental Brands. No reproduction of this document without permission. © Wastecorp.