

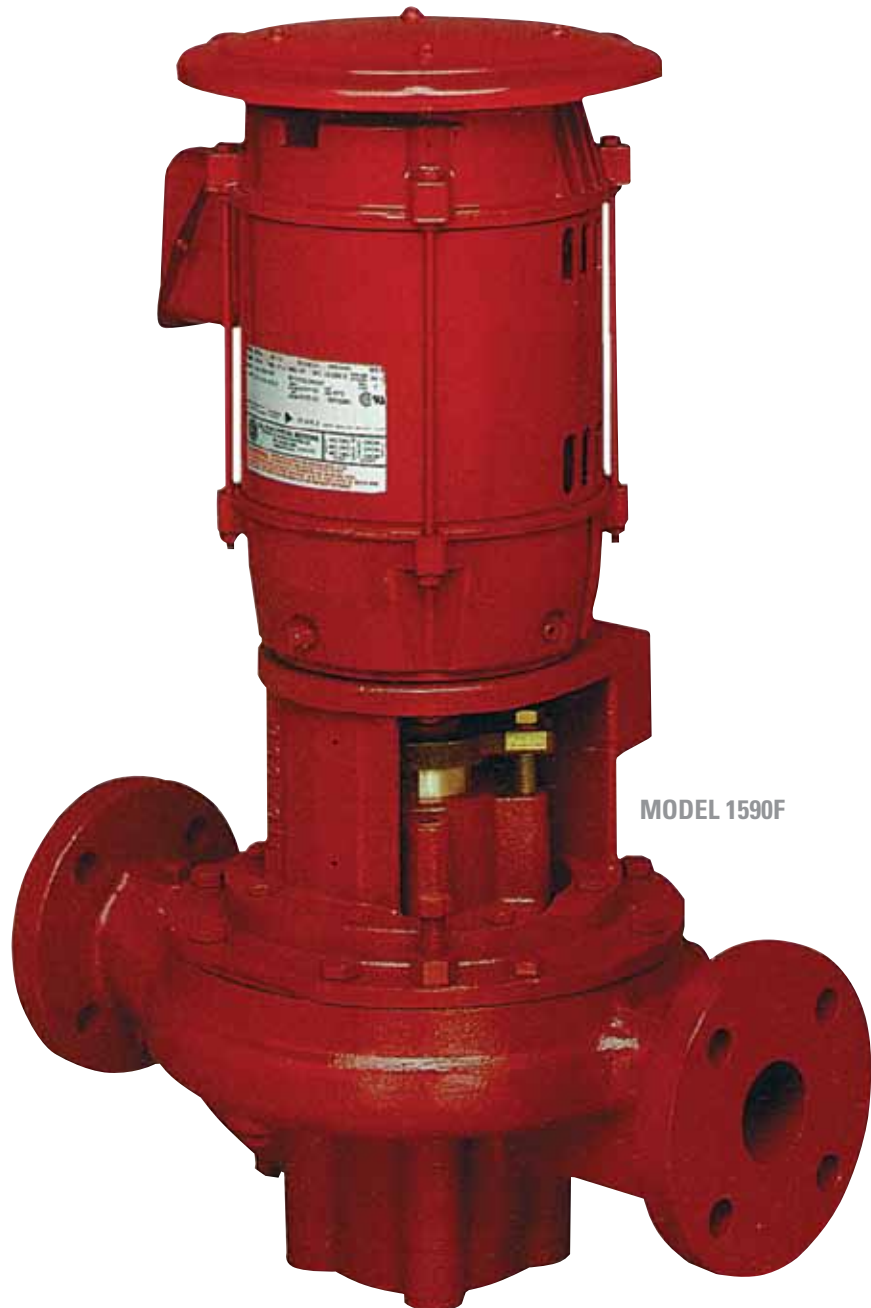

Fairbanks Morse®

Pentair Water

1590F Series Single Stage Inline Fire Pumps



MODEL 1590F

Built Per NFPA 20



Single Stage Inline Fire Pumps

Vertical Inline Close Coupled Fire Pumps are specifically designed for vertical mounting. The suction and discharge nozzles are located on the same centerline 180° apart. Vertical pumps significantly reduce required mounting space. They are easy to maintain. Simply remove eight capscrews and the motor and bracket assembly are easily removed from the casing without disturbing the piping. The impeller is direct coupled to the motor shaft for easy maintenance, to minimize impeller run-out and to reduce noise.

The inline casing is heavily ribbed to resist pipe strain and is provided with a support to simplify mounting to a base or foundation. Packing is provided when suction pressure is greater than 30 psig; packing with lantern ring and flush line is furnished for suction pressures of 30 psig or less. Look through this bulletin for additional details and specifications.

Back pull-out inline case design simplifies disassembly. The suction and discharge piping or alignment is not disturbed as the casing remains in the pipeline. Simply remove the motor and bracket assembly for service or inspection.

Computer machined major components with 360° registered fits assure parts concentricity.



Standard

- Bronze fitted pump construction
- Bronze shaft sleeve
- Split bronze packing gland
- Carbon steel shaft
- 125# ANSI flange drilling
- Dynamically balanced vacuum cast impeller
- Stainless steel impeller screw & washer
- Bronze case wear ring(s)
- Graphite impregnated acrylic packing
- Motor: NEMA-HI JP or TCZ frame
- Factory performance tested in accordance with NFPA-20

Accessories

- Suction and discharge pressure gauges
- Air release valve
- Circulation relief valve
- Hose valve header
- Hose valves
- Flow meter
- Jockey pump
- Optional flange drillings
- 125 lb. suction – 250 lb. discharge
- 250 lb. suction and discharge

Superior Performance

- Flows from 50 to 1500 GPM (11 to 340 m³/hr)
- Pressures from 40 to 155 psi (2.8 to 10.7 bar) and beyond
- Pump design optimized for low HP requirements

1. **Back Pull-Out Casing** with inline suction and discharge.
2. **Case Wear Ring** prevents wear on casing and is easily and inexpensively replaced.
3. **Support** simplifies mounting. The pump can be fastened to the floor, a base or foundation.
4. **Dynamically Balanced Impeller** is keyed to the shaft and secured by a capscrew and washer. Vacuum casting and quality controlled manufacturing process assure consistent high performance. Enclosed design provides high efficiency and low wear for long service life.
5. **Carbon Steel Shaft** is designed for minimum deflection at maximum load.
6. **Two Piece Bronze Packing Gland** provides easy packing maintenance.
7. **Factory Performance Test** guarantees performance at specified pump operating conditions.
8. **Flush Line** with valve (when used) from discharge provides easy water seal adjustment to lantern ring.
9. **Bronze Shaft Sleeve** extends full length of stuffing box to protect motor shaft. The shaft sleeve is slip fit over the shaft and then is keylocked. Shaft sleeve and impeller screw are sealed by O-ring gaskets to eliminate corrosion of the shaft by the pumped liquid.
10. **Standard Motor** approved for 1590F Series pump service by NEMA and the Hydraulic Institute provides low noise level pump operation.
11. **Volute Type Suction** inlet prerotates suction liquid.

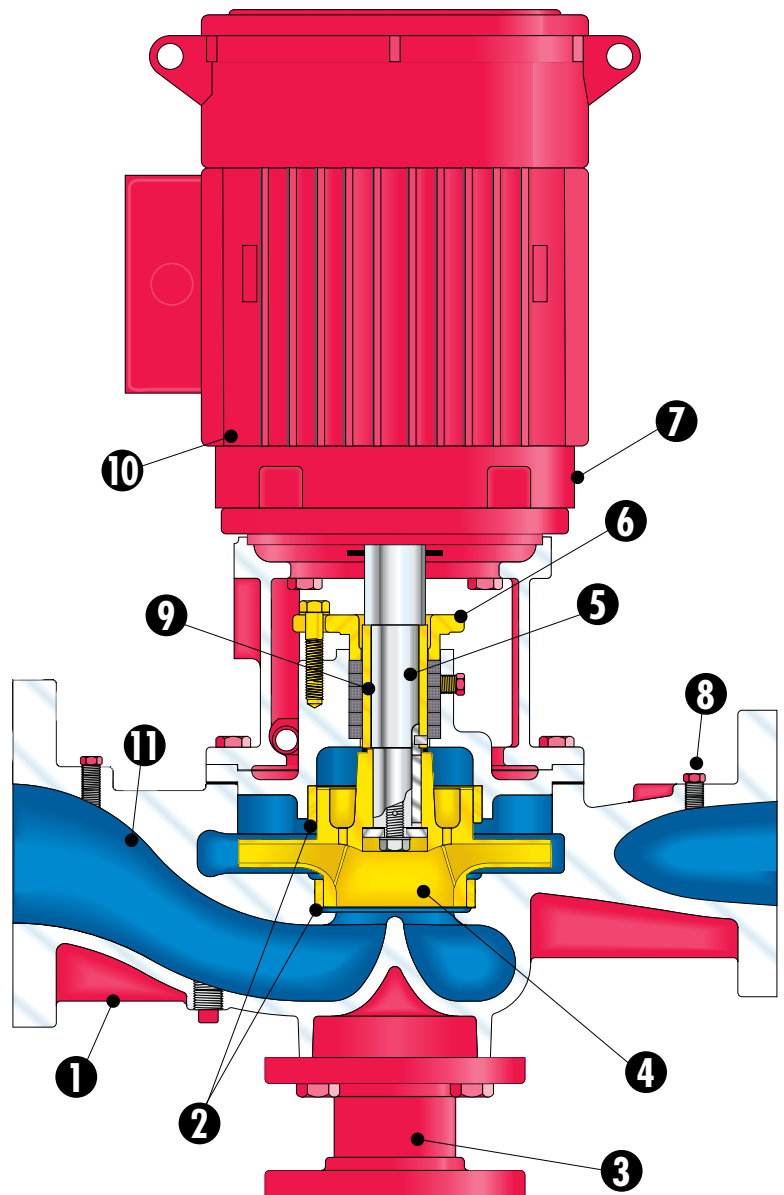

Note: Front case wear rings are standard on all size pumps. Rear case rings are standard on all sizes except the 2x2x9C. The 2x2x9C does not require a wear ring.

ENGINEERING SPECIFICATIONS

Model 1590F Pumps

One Fairbanks Morse Model 1590F vertical inline centrifugal Fire Pump listed by Underwriter's Laboratory and approved by Factory Mutual having a capacity of _____ GPM for a pressure boost of _____ psig. Pressure at the pump suction will be _____ psig, giving a discharge pressure of _____ psig. The pump shall have a bronze impeller, bronze case wear ring, packing gland and shaft sleeve.

The pump discharge flange shall be _____ psi bolt pattern and the suction flange _____ psi bolt pattern. The pump shall be fitted with a Teflon® lantern ring when the suction pressure is 30 psig or less. Pump to be directly connected to a _____ HP _____ RPM vertical, solid shaft, open dripproof motor suitable for an electrical supply of _____ volts, _____ phase and _____ hertz with a 1.15 service factor.

Testing

The pump shall be subjected to an operation test at rated speed. A performance curve showing the flow, total head, brake horsepower and efficiency is to be plotted. Certified curves shall be supplied to the customer. The pump shall be hydrostatically tested at two times the shut-off pressure or 250 psig, whichever is greater.

NOTE: Fairbanks Morse reserves the right to make revisions to its products and their specifications, and to this bulletin and related information, without notice.



800 Airport Road • North Aurora, Illinois 60542 • Phone: 888-987-8680
3601 Fairbanks Avenue • Kansas City, Kansas 66106 • Phone: 888-416-9510

www.fmpump.com

