



Pumps and pumping systems

CPE end-suction single-stage centrifugal pumps ASME B73.1



Main industries and applications

Sulzer's new CPE ANSI pumps are specifically designed to exceed the strictest energy regulations for all industries as well as the requirements of ASME B73.1. With revolutionary hydraulics and high efficiency, they offer the lowest life cycle costs.

CPE pumps meet the process requirements in a variety of industrial applications and are suitable for use with:

- clean or slightly contaminated liquids
- viscous liquids of up to 1'000 cSt (or even more depending on the operating conditions)
- fibrous slurries of up to 6% consistency (depending on the pump size, operating conditions and fiber type)

CPE pumps are available in NSF61 and NSF372 certified materials.

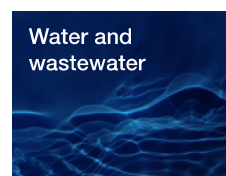
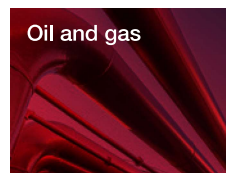

Key customer benefits

Based on Sulzer's decades of experience and in-depth knowledge of pumping technology, the CPE pumps help you maximize value in your operation. Key benefits include maximum energy efficiency, improved performance reliability and minimized total cost of ownership.

Maximum efficiency

- The highest available efficiency on the ANSI pump market means clear savings in energy consumption.
- Exceeds the requirements of all environmental (ECO) directives and the energy efficiency targets for pumps globally

Improved reliability

- Optimized shaft seal life thanks to improved sealing chambers and Sulzer's innovative, patent-pending impeller balancing holes
- Reduced risk of unplanned shutdowns as a result of trouble-free shaft sealing with Sulzer's mechanical seals

- Heavy-duty rigid bearing units ensure long bearing life, leakage-free construction and further protection against unexpected shutdowns.

Minimized total cost of ownership (TCO)

- Dramatic long-term energy savings thanks to high efficiency
- Low operational cost due to trouble-free Sulzer seals, rigid bearings and minimized service
- Reduced inventory as a result of high interchangeability
- Reduced installation and maintenance costs due to easy installation and innovative design.

Specifications

Operating data

Capacities	up to 7'000 USgpm	up to 1'650 m ³ /h
Heads	up to 900 ft.	up to 275 m
Pressures	up to 400 psi	up to 27.5 bar
Temperatures	up to 500°F	up to 260°C
Maximum speed of rotation	up to 3'600 rpm	

Performance range

Liquid	Temperature up to 500°F / 260°C	Pressure up to 400 psi / 27.5 bar	Corrosion pH from 0 to 14
Clean and slightly contaminated liquids	●	●	●
Viscous liquids	●	●	●
Fibrous slurries	●	●	●

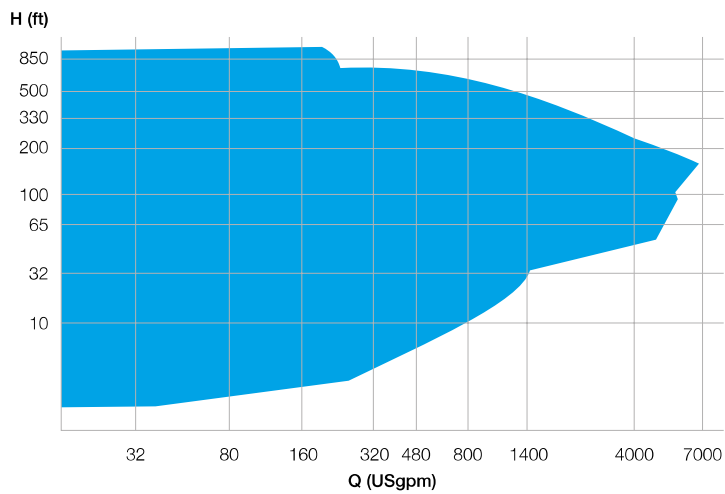

Optimal materials for your applications

Sulzer ANSI pumps are used in a wide range of chemical process applications as well as in general industry. Selecting the best material according to specific process requirements is important for maximizing pump life, especially for aggressive processes where resistance to corrosion and abrasion is vital. Sulzer offers a large variety of material options for our ANSI pumps, ensuring you get the optimal pump for your process.

Stainless steel design			Nominal chemical composition %					
			C max	Cr	Ni	Mo	Cu	N
Duplex	ASTM A890 3A (CD6MN)	41	0.06	24.0-27.0	4.0-6.0	1.75-2.5	-	0.15-0.25
	ASTM A890 5A (CE3MN)	4T	0.03	24.0-26.0	6.0-8.0	4.0-5.0	-	0.10-0.30
Austenitic	ASTM A743 (CN-7M)	43	0.07	19.0-22.0	27.5-30.5	2.0-3.0	3.0-4.0	-
Martensitic	ASTM A747 (CB7Cu-2 H900)	4E	0.07	14.0-15.5	4.5-5.5	-	2.5-3.2	-
Nickel alloy	ASTM A494 (CW-6M)	4J*	0.07	17.0-20.0	balance	17.0-20.0	-	-

* Available with CPT hydraulics

Carbon, low-alloy cast steel, cast iron design			Nominal chemical composition %					
			C	Cr	Ni	Mo	Cu	Si
Ductile iron	ASTM A395 60-40-18	5H	-	-	-	-	-	-

Material alternatives for other parts

Gasket material	Aramid fiber-elastomer	Y6	Used in temperature range -40°C/-40°F...+160°C/+320°F and pH 2-12					
	PTFE/Glass	84	Used in temperature range -190°C/-310°F...+240°C/+464°F and pH 0-14					
	Flexitallic™ Sigma 511	-	Used in temperature range up to +260°C/+500°F					
O-ring material	EPDM	92	Used in temperature range -58...+300°F/ -50...+150°C					
	PTFE	94	Used in temperature range -325...+500°F/ -200...+260°C					

Optimized casting material selection

Pitting in pumps refers to small, deep cavities that can form randomly on wetted surfaces. Crevice corrosion, as the name suggests, occurs in narrow crevices into which a solution can penetrate, but where it is not flushed away during the normal course of operation as happens in more open areas of the pump.

By calculating the sum of the most important alloys in a weighed form, it is possible to identify the susceptibility of specific alloys to pitting and crevice corrosion.

This calculated parameter is called the Pitting Resistance Equivalent (PRE), commonly expressed as $PRE = Cr \% + 3.3 \times Mo \% + 16 \times N \%$. The values in the graph above have been calculated using this formula, with the higher PRE number representing greater resistance to pitting and crevice corrosion.

Typical materials used in chemical process industry and general industry

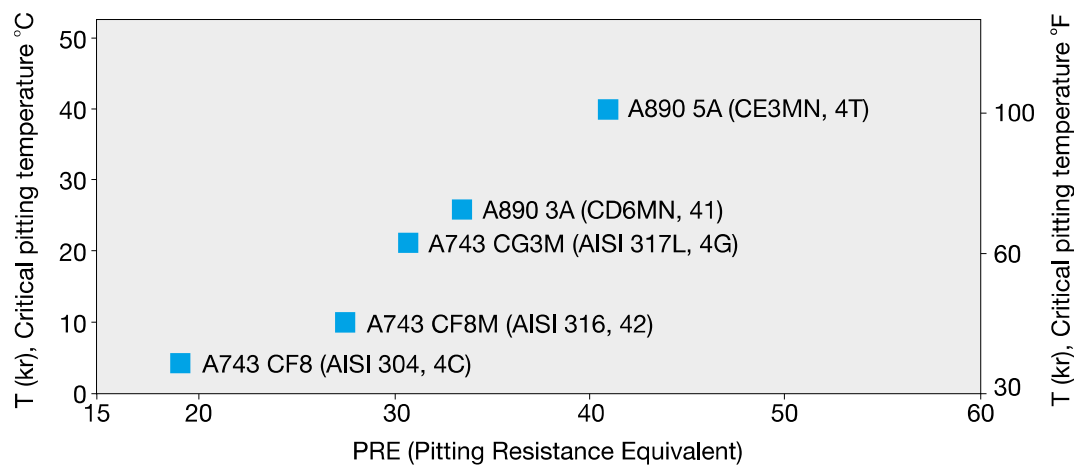

Minimizing total cost of ownership

Total Cost of Ownership (TCO) refers to the true, full cost of your pump – from purchase and installation to lifetime maintenance and operational expenditures. In engineering the new range of CPE pumps, we at Sulzer have considered numerous factors that can potentially influence the TCO of a process pump. The result is an innovative, superior design that makes it possible to achieve remarkable annual savings.

Your initial purchase is only a small part of the entire life cycle price for industrial pumps. Understanding the various elements that go into the TCO for your pump makes it easier to see how you can dramatically reduce energy, operational, and maintenance costs.

The diagram below demonstrates just how great a role energy consumption plays in determining the long-term costs of pumping systems. The right pump technology, properly sized for a specific application, offers an important step for reducing energy consumption and thereby the overall lifetime cost of the pump.

With the market's most efficient hydraulics for ANSI pumps, Sulzer's new CPE pump creates new opportunities for significant, direct savings in energy consumption. The range's wide selection, open and closed impeller options, and available low-flow capabilities make it easy to select the optimal pump for your specific processes. With the right pump for the application, you ensure maximum efficiency for maximum savings.

Selecting the optimal pumping system for your operation also helps to minimize vibrations which can cause mechanical stress. Along with the high standardization in the design of the new CPE range, this enables you to dramatically bring down costs related to maintenance and spare parts.

But that's just the beginning. As the result of Sulzer's extensive research and development, the new CPE pumps include several features designed to help your business keep costs down. Learn more about the ways in which the CPE range helps lower your TCO on the following pages.

Typical distribution of Total Cost of Ownership (TCO)

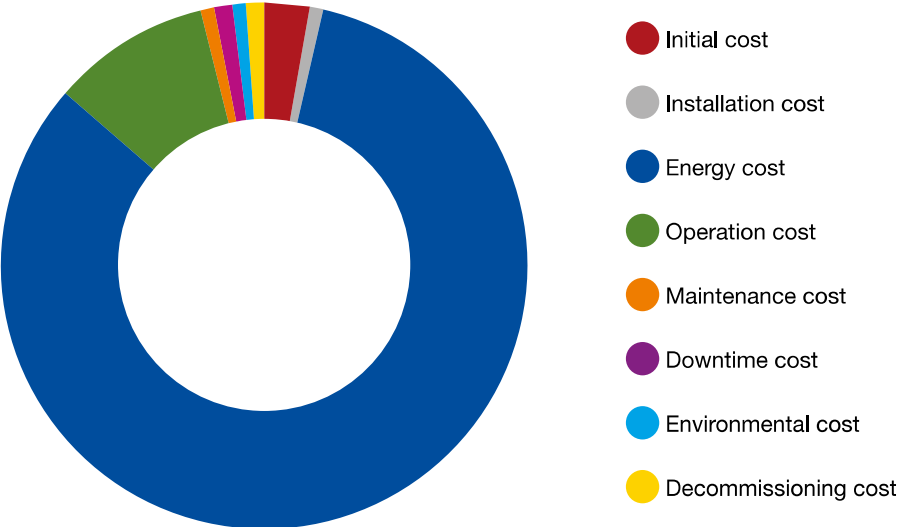

Energy efficiency that exceeds the requirements

Energy efficiency is a hot topic in the industry. So important that authorities worldwide are preparing regulations for that. The CPE process pump is the most efficient process pump in ANSI markets and fulfills all environmental (ECO) directives and energy efficiency requirements for pumps globally.

The entire CPE pump range represents a major breakthrough in energy efficiency. The cost savings are substantial thanks to the many innovations in the design process and Sulzer's unique hydraulic expertise:

- Groundbreaking engineering methods improve pumping performance.
- Effective simulation tools provide quick analyses of various hydraulic designs.
- Full-scale research center allows testing of pumps in real operational conditions.

Excellent performance achieved through advanced hydraulic knowledge and unique design methods

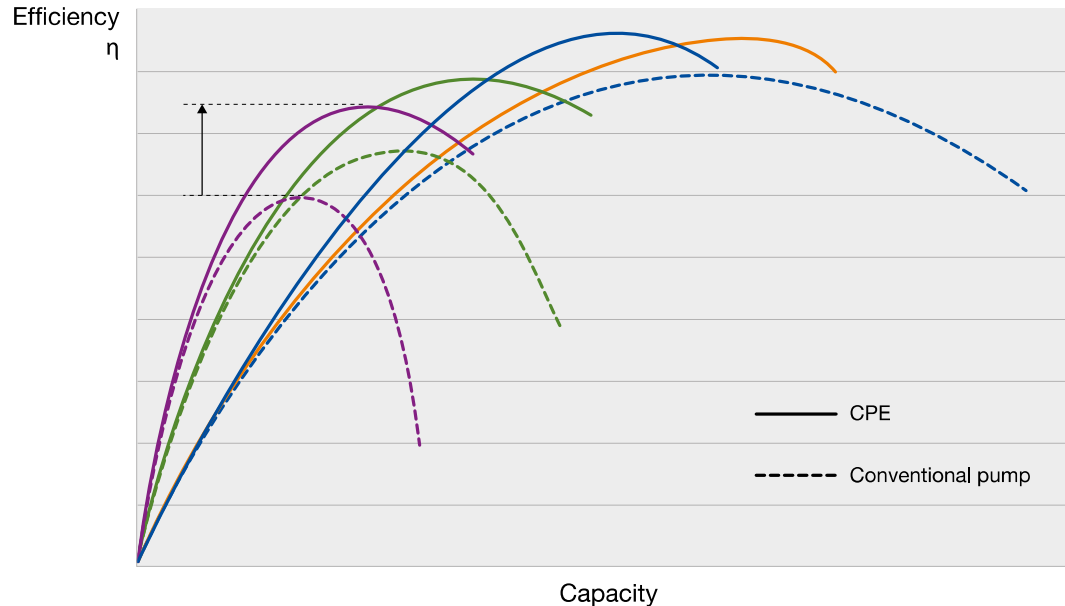

Superior design features of CPE pumps

1 High-efficiency, low NPSHr impeller

- Lowers energy consumption and downtime-related expenses for reduced total cost of ownership

2 Innovative patented impeller balancing holes

- Optimum liquid circulation behind the impeller and in the seal chamber
- Improved conditions for shaft seal, thus reducing the risk of unexpected shutdowns as well as minimizing operational and maintenance costs

3 Optimal impeller mounting

- Reliable operation
- Provides easy and quick assembly and dismantling
- To secure the impeller in back flow situations, an optional impeller bolt is available

4 Various sealing options including

- Sulzer mechanical seals
- Ensure reliable and trouble-free operation
- Provides easy and quick assembly and dismantling
- Reduce total cost of ownership by minimizing maintenance and downtime-related costs

5 Various seal chamber options

- Allow optimal seal chamber selection for your specific process needs
- Reduce total cost of ownership by minimizing maintenance and downtime

6 Heavy-duty bearing unit with oversized bearing design

- Minimizes risk of unexpected shutdowns and reduces maintenance costs
- Available in either oil or grease lubrication
- Exceeds ASME B73.1 requirements for bearing life
- Provides interchangeability with previous ANSI model (CPT)
- Includes magnetic drain plug

7 Heavy-duty, robust overhung shaft

- Minimizes deflection at shaft sealing to less than 0.002 in / 0.5 mm
- Extends the shaft seal lifetime, reduces the risk of unexpected shutdowns and lowers maintenance costs
- Duplex stainless steel material is standard

8 Non-contacting bearing protection isolators

- Prevent lubricant leaks
- Extend bearing lifetime
- Prevent outside contaminants from entering the bearing housing
- Minimize the risk of unexpected shutdowns and lower maintenance costs

9 Impeller clearance adjustment

- Ensures easy-to-use, accurate operation
- Enables maximized efficiency during entire pump lifetime
- Offers substantial savings in total cost of ownership

Various baseplate options

- Provide optimal selection for all industries and applications
- Ensure easy and fast installation
- Offer savings in installation costs

Highly standardized pump design

- Minimizes spare parts inventory and lowers maintenance costs

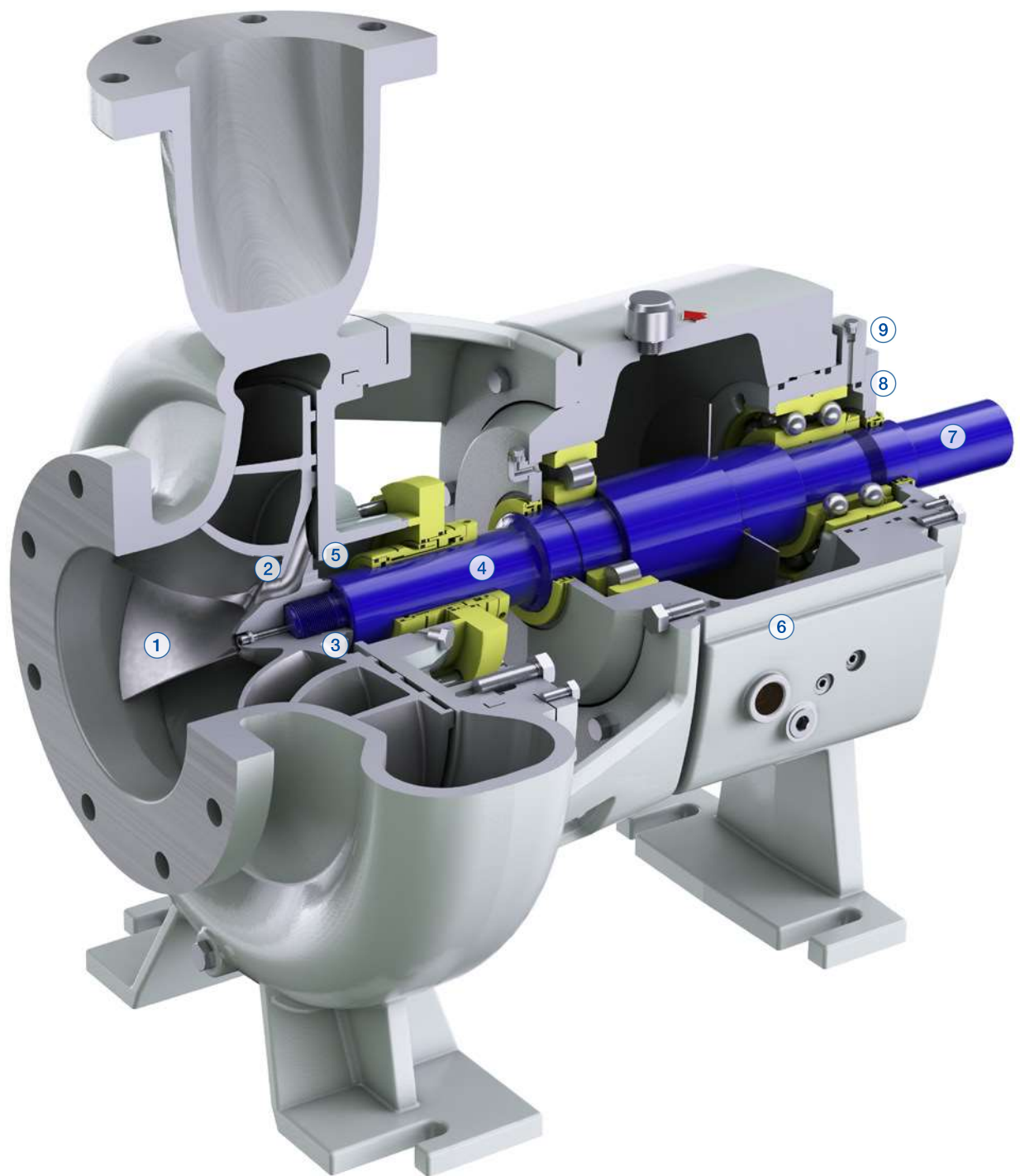

Impeller

The efficiency, stability and reliability of the pump are based on the design. Sulzer CPE pumps feature an innovative impeller designed in tandem with the volute case and sealing chamber. The result is the market's most efficient hydraulics with improved shaft sealing for higher reliability. Semi-open and closed impellers offer versatility for various liquids, maximizing standardization to minimize your need for spare parts.

Semi-open impeller for clean, fibrous and viscous liquids

- Extremely high efficiency
- Low Net Positive Suction Head required (NPSHr)
- Capability for low-flow applications
- Full back shroud
- Sturdy and strong design
- Optimized balancing holes



Closed impeller for clean and viscous liquids

- Extremely high efficiency
- Low Net Positive Suction Head required (NPSHr)
- Optimized for low-flow applications
- Sturdy and strong design

Unique, patented balancing holes

- Dry running of the single mechanical seal is eliminated for the entire pump operating range.
- Optimized flow and pressure in the shaft sealing area
- Increased reliability, reduced risk of downtime and lower maintenance costs

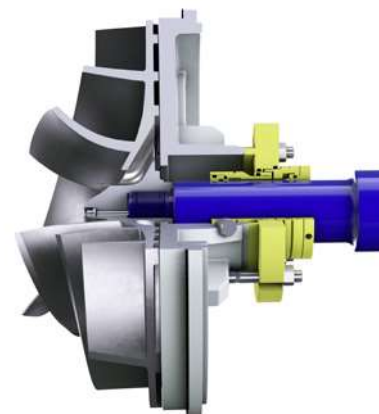

Reliable impeller mounting

- Impeller threaded to the shaft according to ASME B73.1 standard
- Optional impeller locking bolt is available.
- High mechanical strength
- Reliable and easy installation
- Minimized downtime and reduced maintenance costs

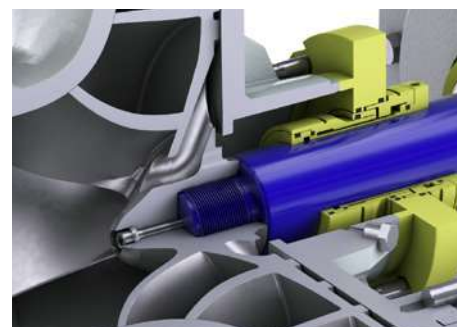

Low-flow applications

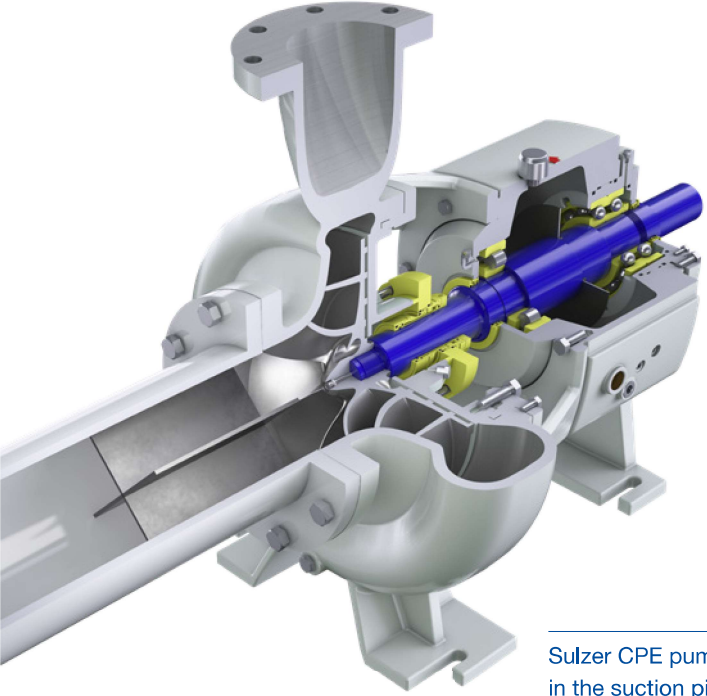

Sulzer CPE pump with flow straightener in the suction pipe for low flows

Now you do not need a special pump or impeller to run low flows! The innovative design of Sulzer's CPE pump hydraulics is optimized to run low flows with a standard impeller.

The CPE pump range provides optimal low-flow performance without any mechanical risks. You can run the pump with a wide range starting from 5% of BEP flow (Best Efficiency Point).

If you are running low flows (between 5 and 55% of BEP flow), it is recommended to install a flow straightener in the suction pipe to ensure stable, trouble-free operation with the highest possible efficiency.

Sulzer can provide flow straighteners with complete delivery to ensure fast and easy installation and reliable, long-term performance.

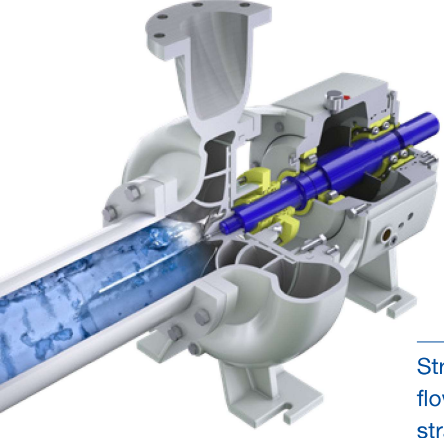

Straight and smooth inlet flow with the help of flow straightener

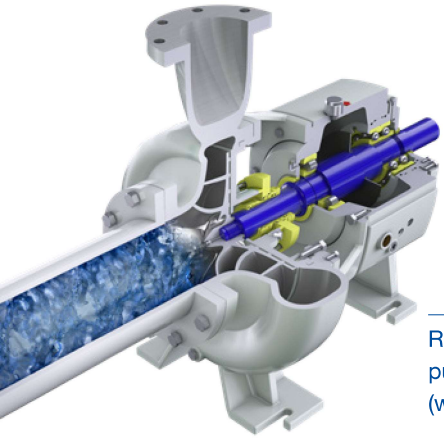

Rotating inlet flow causing pumping problems (without flow straightener)

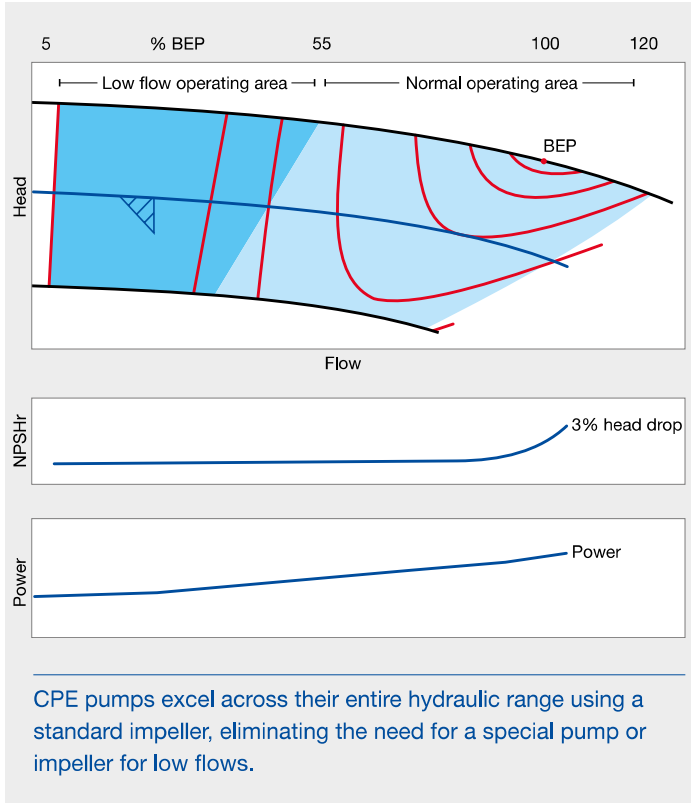

CPE pumps excel across their entire hydraulic range using a standard impeller, eliminating the need for a special pump or impeller for low flows.

Shaft sealing

Shaft sealing has a great influence on pump reliability. Therefore it is essential to select the best technical solution for your specific application. For the CPE pump range, Sulzer offers a comprehensive selection of seals and seal chamber options to make sure your pump is fully optimized to your process for the highest possible uptime.

Mechanical seal

- Single and double seals available
- Flushing options: no flushing, internal flushing, external flushing
- Suitable for all applications compatible with the CPE range
- Reliable and strong Sulzer mechanical seals available

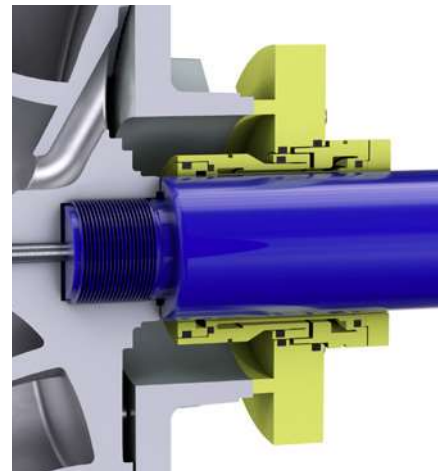

Sulzer dynamic seal

- Dynamic seal needs no water
- Suitable for applications with positive pump inlet head and a temperature below boiling point under atmospheric pressure
- Suitable for clean liquids, viscous and fibrous slurries and liquids containing large solids

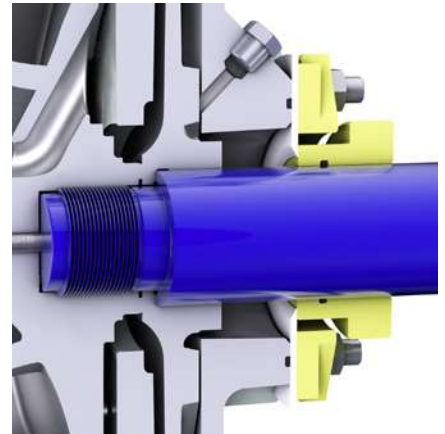

Gland packing

- Suitable for light-duty applications, including those with clean or slightly contaminated liquids

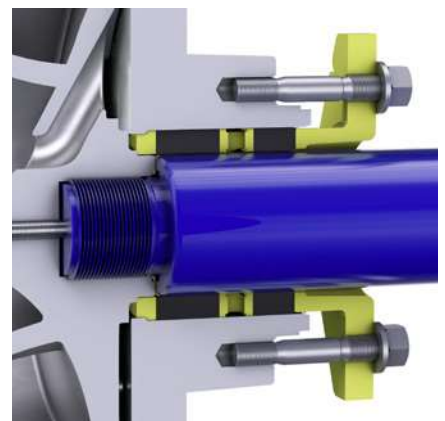

Seal chambers

A complete variety of seals and various seal chamber options is available for the CPE pump range to ensure optimal shaft sealing, maximizing operational reliability and minimizing downtime costs.

Standard bore

- For clean liquids, liquids containing particles and slurries
- For single or double mechanical seals and gland packing

Tapered bore

- For clean and demanding liquids
- For single or double mechanical seals

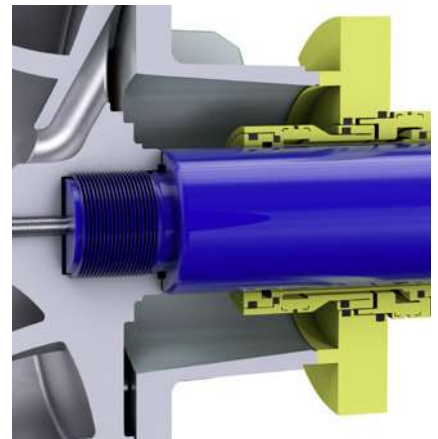
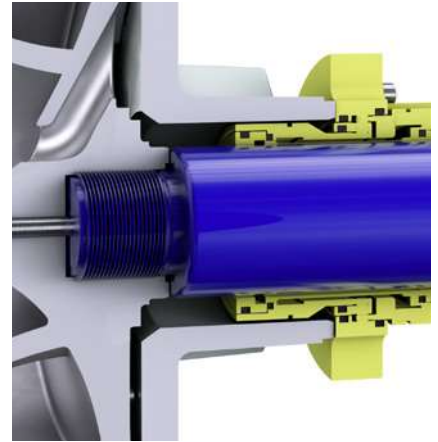
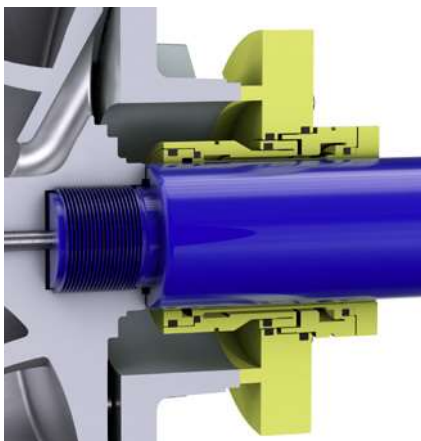
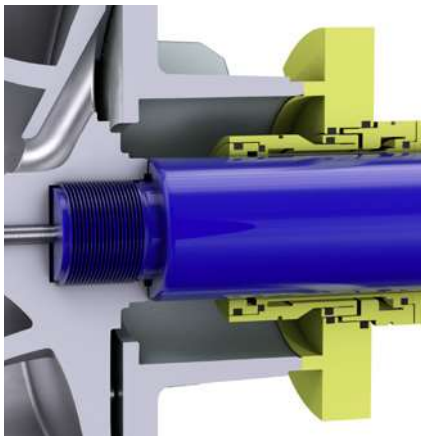

Large bore

- For clean liquids, liquids containing particles and slurries
- For single or double mechanical seals
- The oversized chamber helps reduce running temperatures while improving lubrication and circulation

Universal bore

- For clean liquids
- For single or double mechanical seals

Compact heavy-duty bearing units

CPE bearing units are reliable, leakage-free and heavy-duty, resulting in minimized unexpected shutdowns and reduced downtime and maintenance costs.

- Heavy-duty overhung shaft minimizes deflection at stuffing box to less than 0.002 in / 0.05 mm, thereby extending the lifecycle of the shaft seal.
- Oil bath lubrication equipped with an oil slinger, oil mist lubrication, and grease lubrication are available for versatile applications with temperatures of the pumped liquid of up to 500°F/260°C
- The same bearing unit can be used for oil and grease lubrication without changing or adding any internal parts.
- Bigger oil volume for even better lubrication with lower operating temperatures
- Features a magnetic drain plug
- Large oil sight glasses enable easy oil level monitoring on both sides of bearing unit.
- The strong, over-sized bearing design exceeds the ASME B73.1 standard bearing life.
- A sturdy support foot provides a solid base and prevents coupling alignment changes.
- Interchangeable with original Sulzer CPT pump bearing unit

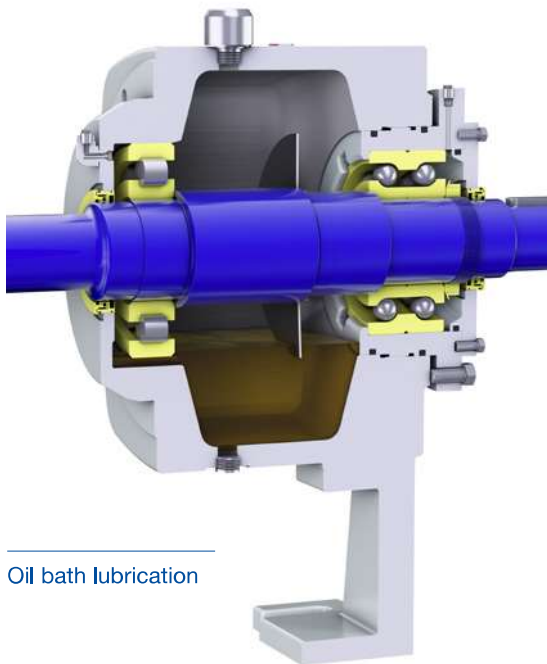

Oil bath lubrication



Grease lubrication

Reliable bearing isolators

Non-contacting bearing isolators at both ends of the bearing housing with strong and reliable construction prevent lubricant leaks and keep contaminants out.

The isolators are easy to install and always stay in the correct position.

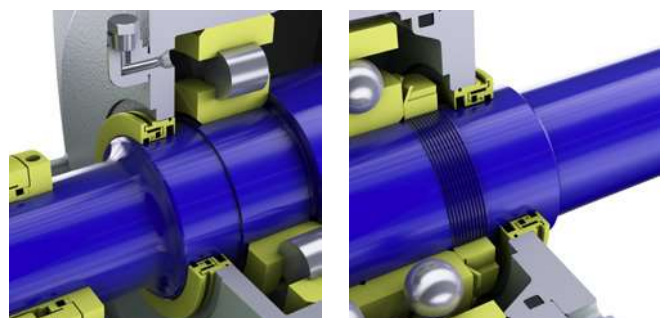

Impeller clearance adjustment

Externally adjustable impeller to front casing clearance allows restoring the pump to its original efficiency. This helps further minimize long-term energy consumption and maintenance costs.

- Ensures quick, easy and accurate impeller adjustment without the use of a feeler gauge or removal of the pump from the piping.
- Ensures concentricity and bearing alignment throughout the impeller's adjustment range.
- Restores pump efficiency for direct savings in energy and spare parts costs.

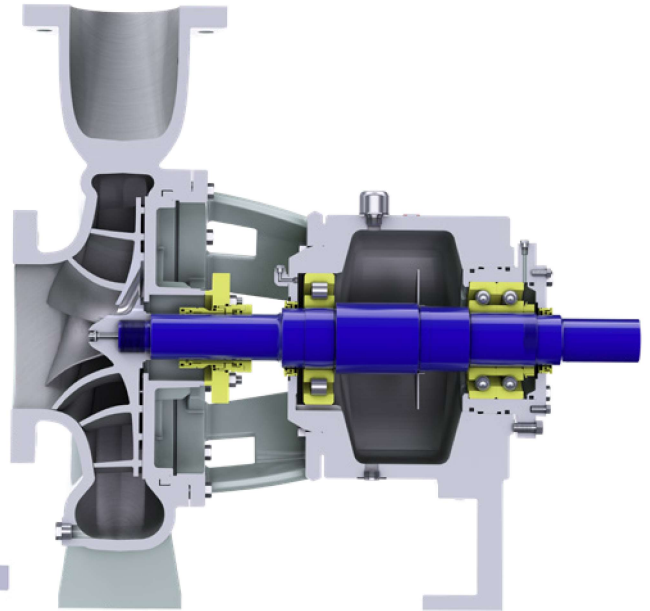

Installation, operation and maintenance

1 Various baseplate options

- Easy to install and grout into the concrete foundation
- Lower vibration and reduced wear and tear

2 Guards for the rotating parts

- Designed according to stringent safety regulations
- Ensure safe and reliable operation

3 Visual access on both sides of the guards

- Provides safe and easy stroboscope inspection of the coupling during operation

4 Flexible coupling with spacer

- Provides quick and easy maintenance

5 Back pull-out design

- Facilitates quick access for servicing

6 Jackscrews

- Enable simple disassembly of the main parts of the unit while minimizing maintenance costs

7 Foundation bolts according to preferred installation method

- Can be welded, grouted or installed with chemical anchors

8 High-efficiency motor

- Available with both NEMA and IEC motors

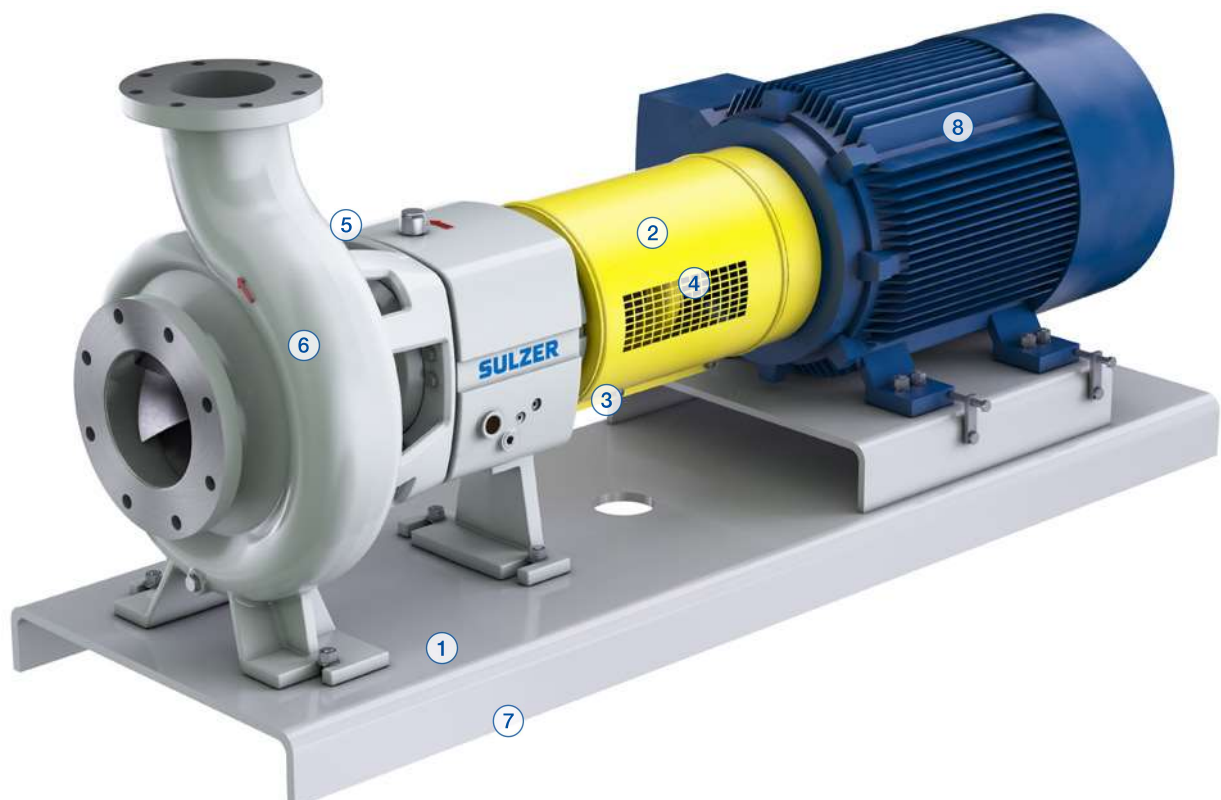

Baseplate options

Various baseplate options are available to meet any needs. Sulzer baseplates are robust and rigid, designed for easy and quick installation of a pump-motor combination.

Standard baseplate

Sulzer standard formed steel baseplates meet ANSI specifications for pump/motor mounting. A single grout hole and epoxy paint are standard. Options include a stainless steel drip pan and 100% stainless steel construction.



Drip-lip baseplate

The drip-lip baseplate with welded end caps includes a sloped drainage channel to a welded drain connection making this an excellent upgrade to the standard baseplate. Options include motor adjustment bolts, additional grout vent holes and 100% stainless steel construction.



PIP baseplate

This baseplate is designed to current PIP requirements and comes standard with a grout hole, raised mounting pads, motor alignment bolts, additional welded supports, a sloped full-drain pan, lifting lugs and continuous welded steel construction.

Options include leveling stilt and spring mounting and 100% stainless steel construction.



Non-metallic baseplate

The non-metallic polymer composite frame-mounted pump bases are designed for frame-mounted ANSI/ASME pump combinations. They meet ANSI/ASME B73.1 specifications. The polymer baseplate is the best value in the industry.



API baseplate

This baseplate is designed according to API requirements for pump/motor mounting. Possible leaks are collected on the baseplate. Standard riser blocks enable the installation of larger drive motor frames as required. Motor adjustment bolts are included to facilitate fast, simple adjustment of the motor when aligning the coupling.



High standardization and interchangeability

The Sulzer CPE pump range is standardized, using common modules and components for maximum interchangeability, easy installation and maintenance. Fewer parts mean lower inventory costs and greater process reliability.

Common components and modules in the CPE range with all options include:

- 40 wet-end hydraulics
- 2 impeller types
- 4 shaft seal bore types
- 3 shaft seal sizes
- 3 bearing unit sizes
- sealing water equipment
- couplings and coupling guards
- baseplates

Sulzer CPE pumps are interchangeable with older CPT pumps, and the CPE hydraulics can also be installed on an existing CPT bearing unit. By upgrading an existing CPT pump with high-efficiency CPE hydraulics, you get direct savings as a result of improved energy efficiency. In addition, the CPE bearing unit is fully interchangeable with existing CPT bearing units.



Size	Sealing and bearing unit
11-1	
11-1.5	
11-2	①
12-1	
12-1.5	
21-1.5	
21-2	
21-3	
22-1	
22-1.5	
22-2	②
22-3	
22-4	
24-1.5	
24-2	
24-3	
24-4	
31-6	
31-8	
32-4	
32-6	③
32-8	
33-4	
33-6	
33-8	

Heating jacket for thermal maintenance

The CPE pump is designed to meet the process requirements in a variety of industrial applications. Many of these applications require a specific liquid temperature to enable smooth pumping. The new heating jacket ensures uniform heat transfer to the pump for the purposes of thermal maintenance, heat-up/melt-out, or cooling.

Heating/cooling is typically accomplished with steam or water. The correct temperature of the pumped liquid prevents

- undesired sedimentation
- crystal growth
- solidification of the fluid handled

Heating jacket benefits

Sulzer's heating jacket is a cost-competitive, smart and safe solution. It provides evenly-distributed heating across the entire pump. The installation is quick and easy, and so is the removal if the pump needs service.

Complete heating

Provides evenly-distributed heating across the entire pump.

Quick and easy installation

Quick and easy installation and removal when servicing the pump. No welding so no risk of deformation.

Cost-effective

Most economical option when considering total cost of ownership. Standard CPE pump can be used for pumping.

Short lead time

Heating jackets are manufactured at the same time with the process pump enabling a short lead time.



Standard CPE pump selected for jacketed processes

Same spare parts will apply as with other CPE pumps used in the mill.

Heating jacket concept

Our heating jacket concept consists of a heating jacket and a jacketed case cover. The heating jacket covers all wetted parts of the pump and is bolted onto it. The jacketed case cover keeps the desired temperature in the sealing chamber, minimizing the risk of seal failures. Steam or water that regulates the temperature is circulated in heating channels to heat up or cool down the wetted parts and sealing chamber of the pump.

1 Standard CPE pump

- Pump selected for the needed duty point
- Material of construction and seal selected according to application requirements

2 Jacketed case cover

- Keeps the sealing chamber at the desired temperature minimizing the risk of seal failures

3 Heating jacket

- Covers the pump casing and is bolted onto the pump
- Easy installation and removal
- Steam or water supply for heating/cooling

4 Standard bearing unit

Grease lubrication

- Temperature of pumped liquid max. 250°F / 120°C

Oil lubrication

- Temperature of pumped liquid max. 500°F / 260°C
- Optional cooling allows higher temperatures

5 Bearing house adapter

- Holes for case cover heating pipes



Heating jacket design

Sulzer heating jackets are cast of ASTM B179 Grade A 356.2 copper-free aluminum to fit to the pump. A carbon steel pressure chamber is embedded in the aluminum casting to contain the heating medium. The aluminum casting is not designed to hold pressure, it only promotes uniform heat transfer around the pump.

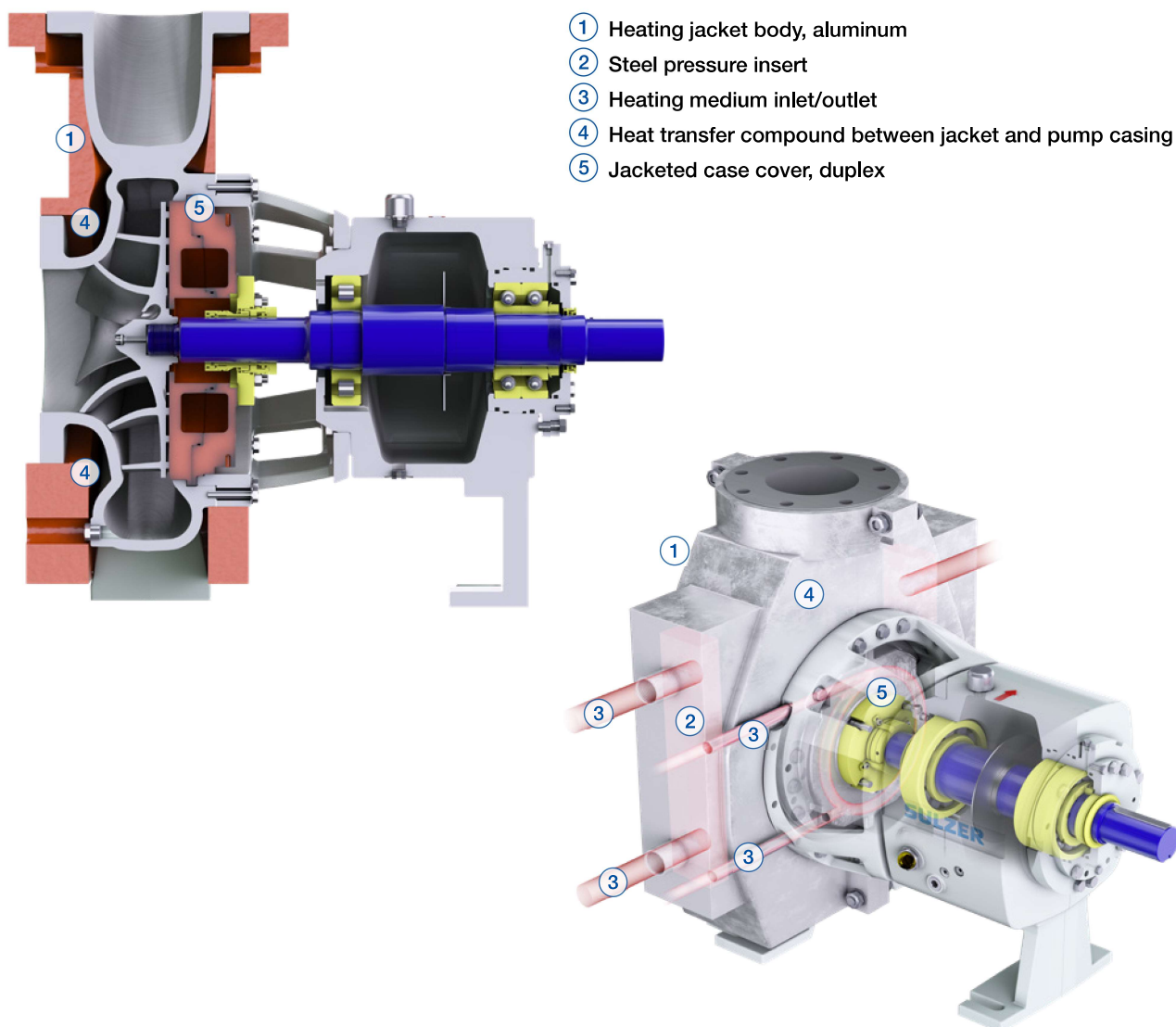

- ① Heating jacket body, aluminum
- ② Steel pressure insert
- ③ Heating medium inlet/outlet
- ④ Heat transfer compound between jacket and pump casing
- ⑤ Jacketed case cover, duplex

Technical data

Component	Data
Heating jacket	Aluminum (ASTM B179 Grade A 356)
Pressure-containing insert (heating jacket)	Carbon steel (ASME rated SA-178 Grade A Boiler Tube)
Jacketed case cover	Duplex stainless steel (ASTM A890 Grade 3A)
Heating / cooling	Steam / water

Service kits for CPE pumps

When your pump needs service, you should not have to worry about spending valuable time searching for the right parts – or even worse, finding out that some small but vital parts are missing. With Sulzer CPE service kits, you get everything you need in one package.

Tailor-made service solution

Sulzer offers four tailored service kits for CPE pumps to help and simplify service tasks. Kits are available for impeller, bearing unit, dynamic seal and gland packing service. All the required O-rings and other small parts are in one package for specific service.

Easy to order and use

One unique item code covering all the items in the kit makes purchasing quick and convenient. Sturdy packaging protects the individual items from damage and can be recycled after use.

Key customer benefits

- All the necessary parts in one package
- Easy to order
- Easy to identify and use
- Reduced inventories
- Original spare parts ensure compatibility, reliability and reduced lifecycle costs.



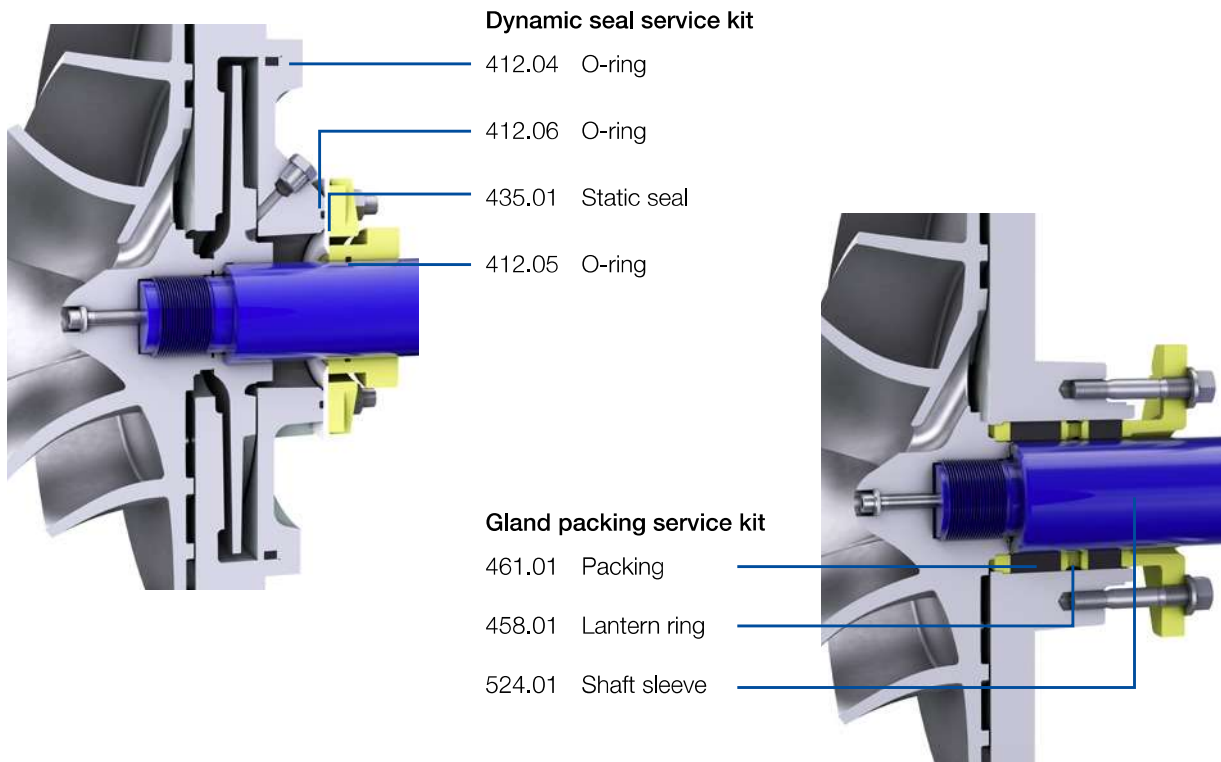
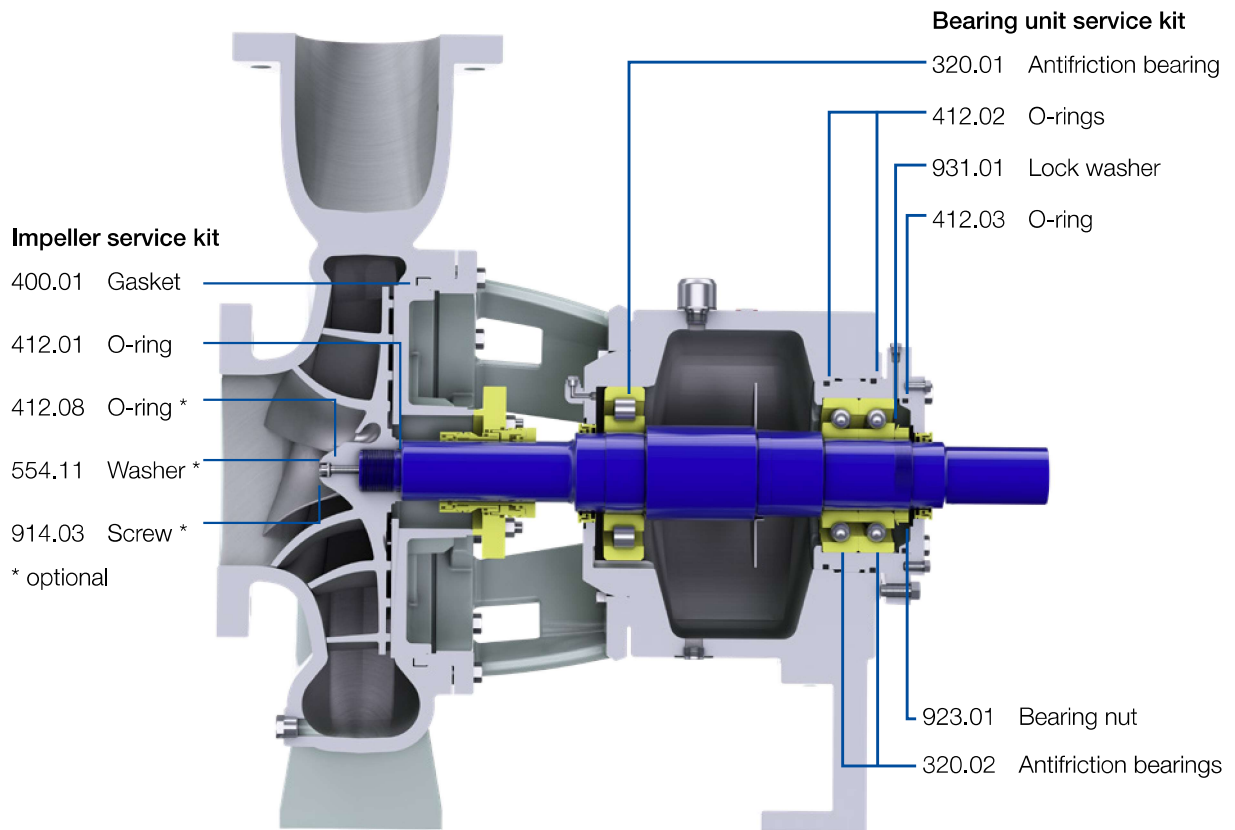

The Sulzer Flow division keeps your processes flowing. Wherever fluids are treated, pumped, or mixed, we deliver highly innovative and reliable solutions for the most demanding applications.

The Flow division specializes in pumping solutions specifically engineered for the processes of our customers. We provide pumps, agitators, compressors, grinders, screens and filters developed through intensive research and development in fluid dynamics and advanced materials. We are a market leader in pumping solutions for water, oil and gas, power, chemicals and most industrial segments.

E10431 en 9.2024, Copyright © Sulzer Ltd 2024

This brochure is a general presentation. It does not provide any warranty or guarantee of any kind. Please, contact us for a description of the warranties and guarantees offered with our products. Directions for use and safety will be given separately. All information herein is subject to change without notice.

